

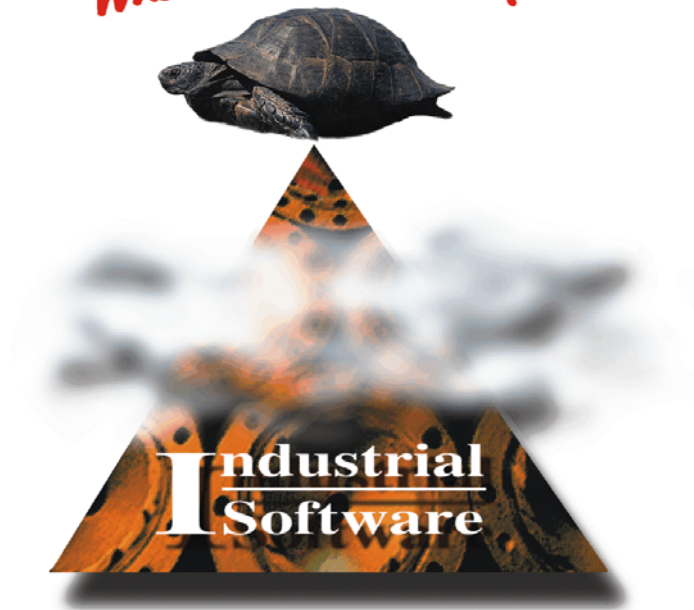

# DP\_LON LINK User's Manual

Pre-release

*What is "perfection"?!*



Revision May 2003

**Industrial Software Ltd.**

45, Lokorska Str.

1225, Sofia, BULGARIA

Phone/Fax: (+359 2) 975 11 80/1/2/3/4

E-mail: [indsoft@einet.bg](mailto:indsoft@einet.bg)

[www.indsoft.bg](http://www.indsoft.bg)



# CONTENTS

## CHAPTER 1. *DP\_LON LINK* PROFIBUS TO LONWORKS GATEWAY SPECIFICATIONS

1.1.	<i>DP_LON LINK</i> TECHNICAL CHARACTERISTICS .....	1-1
1.2.	<i>DP_LON LINK</i> GENERAL DESCRIPTION .....	1-1
1.3.	<i>DP_LON LINK</i> DIMENSIONS .....	1-1









## CHAPTER 2. *DP\_LON LINK* CONNECTIONS

2.1.	<i>DP_LON LINK</i> POWER SUPPLY .....	2-1
2.2.	CONNECTION OF THE <i>DP_LON LINK</i> TO PROFIBUS DP NETWORK .....	2-
2.3.	CONNECTION OF THE <i>DP_LON LINK</i> TO A LONWORKS NETWORK .....	2-

## CHAPTER 3. PRINCIPALS OF DATA ROUTING

3.1.	DP SIDE BUFFER NAMING .....	3-1
3.2.	“HARD” DATA ROUTING .....	3-
3.3.	“TABLE BASED” DATA ROUTING .....	3-

## CHAPTER 4. KEYBOARD AND LCD DISPLAY

4.1.	KEYBOARD AND LCD BASICS .....	4-1
4.1.1.	 Button .....	4-
4.1.2.	 And  Buttons .....	4-
4.1.3.	 And  Buttons .....	4-
4.2.	DISPLAY AFTER POWER UP .....	4-
4.3.	CHANGING MAIN MENU, USING  BUTTON .....	4-
4.4.	USING  AND  TO CHANGE SUBMENU .....	4-
4.4.1	LonWorks Menu & Submenus .....	4-
4.4.1.1.	Neuron ID .....	4-
4.4.1.2.	Ver/Transceiver type/Subnet/Node .....	4-

4.4.2.	ProfiBus Menu & Submenus .....	4-
4.4.2.1.	ProfiBus Address Submenu .....	4-
4.4.2.2.	DP Control/Baudrate Submenu .....	4-
4.4.3.	Input Data Menu .....	4-
4.4.4.	Output Data Menu.....	4-
<b>4.5.</b>	<b>CONFIGURING PROFIBUS SIDE PARAMETERS .....</b>	<b>4-</b>
4.5.1.	Baudrate .....	4-
4.5.2.	DP Address Setting.....	4-
4.5.2.1.	DP Address Setting via LonWorks Configuration Tool .....	4-
4.5.2.2.	DP Address Setting via Keyboard.....	4-

## **CHAPTER 5. GSD FILE**

## **CHAPTER 6. PREPARING SIEMENS STEP7 DEVELOPMENT ENVIRONMENT FOR USING *DP\_LON LINK***

## **CHAPTER 7. USING *DP\_LON LINK* IN CONVEYOR CONTROL SYSTEMS**



# CHAPTER 1

## ***DP\_LON LINK* PROFIBUS TO LONWORKS GATEWAY SPECIFICATIONS**

---

- 1.1. ***DP\_LON LINK* TECHNICAL CHARACTERISTICS**
- 1.2. ***DP\_LON LINK* GENERAL DESCRIPTION**
- 1.3. ***DP\_LON LINK* DIMENSIONS**



## 1.1. DP\_LON LINK TECHNICAL CHARACTERISTICS

Table1.1

PARAMETER	RANGE (SPEC'S) DESCRIPTION
<b>Power Supply Voltage</b>	
- Nominal power supply voltage	24 V DC (rectified, filtered, with maximum ripples 300 mV peak-to-peak)
- Power supply voltage range	18 to 30 V DC
- Current consumption	150mA max.
- Connector	Terminal 1.5 mm <sup>2</sup>
<b>ProfiBus DP Interface</b>	
- ProfiBus DP Slave functionality	
- Internally powered, "flying ground", galvanically isolated	
- Max. baudrate supported	12Mbits/sec.
- Connector	9 way, sub D, plug connector
<b>LonWorks Interface</b>	
- FTT-10 or TPT/XF1250 interface	
<b>Environment specifications</b>	
<b>Protection</b>	IP20
<b>Nominal temperature range</b>	-20°C to 65°C
<b>Conditions for transportation and storage</b>	Temperature: -20°C to 85°C Humidity: up to 90% RH FRAGILE!
<b>Electromagnetic compatibility</b>	IEC 1131 – 2, IEC 801 – Level 2
<b>Dimensions</b>	153mm x 125mm x 60mm
<b>Mounting</b>	DIN Rail
<b>Weight</b>	about 250g

## 1.2. DP\_LON LINK GENERAL DESCRIPTION

The front view of the *DP\_LON LINK* is shown in Fig. 1.1.

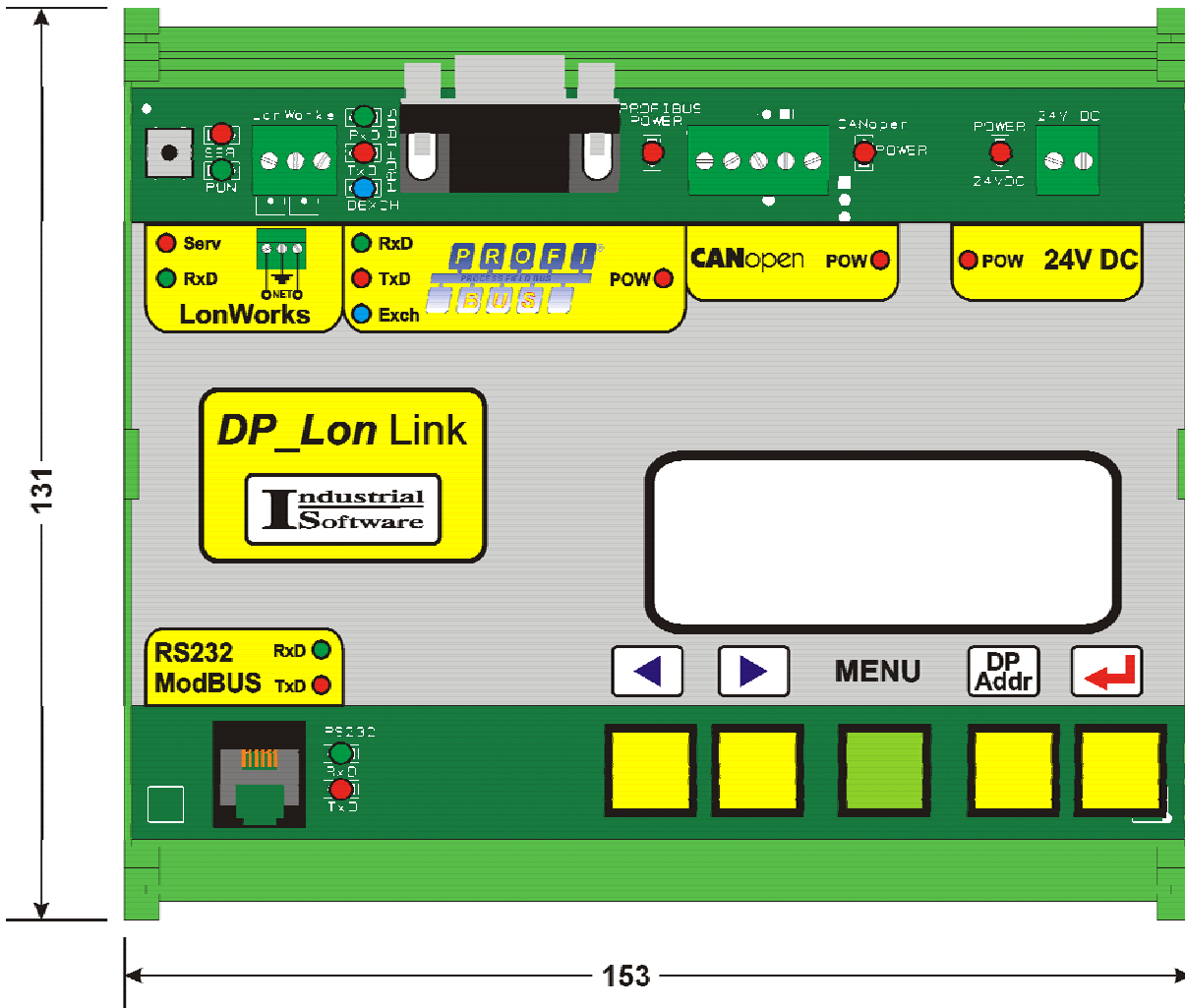

Fig. 1.1

Each *DP\_LON LINK* provides following features:

- Connector for 24V DC power supply.
- Power LED indicator.
- Connector for LonWorks interface.
- LonWorks service pin button
- LonWorks service LED
- LonWorks side “RUN” LED
- Connector for Profibus DP interface.
- DP transmit LED
- DP receive LED
- DP Exchange LED (Master Found)

- LCD Display for data monitoring/diagnostics/DP Address configuration.
- 5 buttons for LCD menu/submenu select, DP address configuration and ENTER.
- CANopen connector & Led – not applicable for ***DP\_LON LINK***.
- Modbus connector & Led - not applicable for ***DP\_LON LINK***.

### **1.3. *DP\_LON LINK* DIMENSIONS**

***DP\_LON LINK*** is assembled on a DIN rail.

***DP\_LON LINK*** has the following dimensions:

Width – 153 mm

Height – 125 mm

Thickness (including connectors) – 60 mm





# CHAPTER 2

## *DP\_LON LINK* CONNECTIONS

---

- 2.1. *DP\_LON LINK* POWER SUPPLY
- 2.2. CONNECTION OF THE *DP\_LON LINK* TO PROFIBUS DP NETWORK
- 2.3. CONNECTION OF THE *DP\_LON LINK* TO A LONWORKS NETWORK



## 2.1. DP\_LON LINK POWER SUPPLY

The **DP\_LON LINK** is powered by 24 V DC (Fig. 2.1), whereas the power supply voltage is subject to the following requirements:

- rectified;
- filtered;
- max. ripples 300 mV peak-to-peak

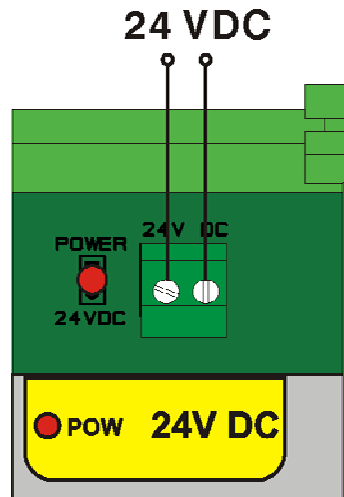

Fig. 2.1

The power supply of the **DP\_LON LINK** is galvanically isolated from the power supply of the processor, LonWorks and ProfiBus.

Table 2.1

Connector	Type	Description
<p>24 V</p> 	terminal 1.5 mm <sup>2</sup>	1,2 - <b>DP_LON LINK</b> power supply, polarity insensitive

Table 2.2

LED	Type	Description
POWER	RED	LED ON shows that the power supply voltage is connected; LED OFF shows the absence of power supply voltage

## 2.2. CONNECTION OF THE *DP\_LON LINK* TO PROFIBUS DP NETWORK

*DP\_LON LINK* is connected to DP Network via 9-way connector.

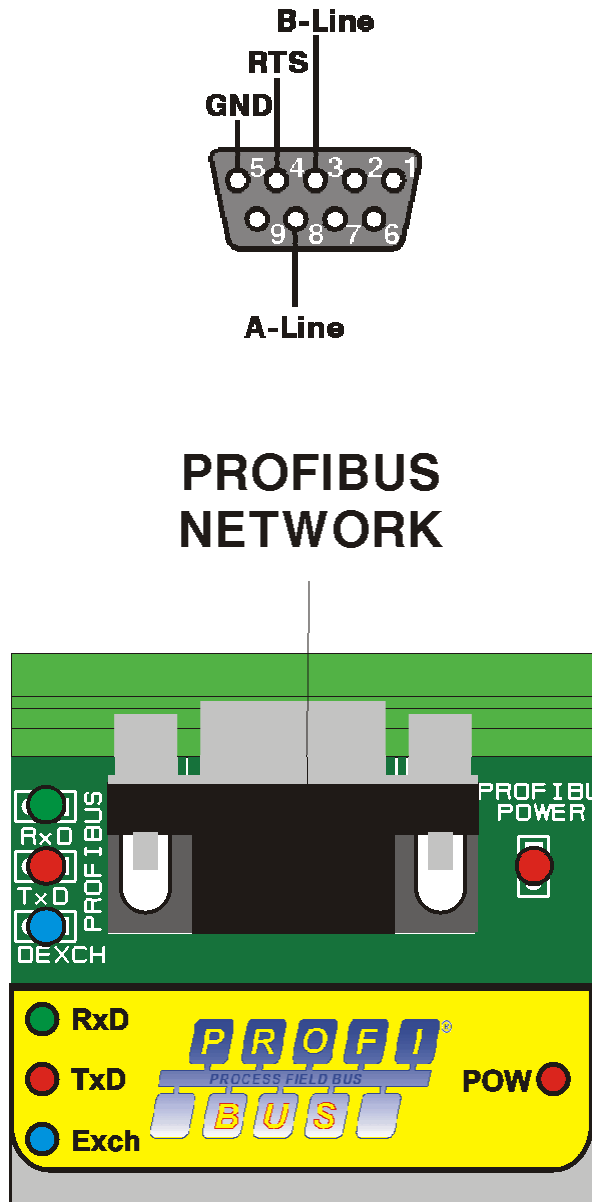

Fig. 2.2

Table 2.3

Connector	Type	Description
ProfiBus	9 way, sub D, plug connector	ProfiBus communication

LED	Type	Description
RxD	GREEN	ProfiBus receive
TxD	RED	ProfiBus transmit
Exchange	BLUE	ProfiBus exchange LED ON - Master found and normal exchange in progress LED OFF – Master not found
POW	RED	LED ON – ProfiBus isolated power supply OK

### 2.3. CONNECTION OF THE *DP\_LON LINK* TO A LONWORKS NETWORK

*DP\_LON LINK* is connected to a LonWorks network by means of three-wire line (Fig. 2.3). The two outer terminals are connected to FTT-10 or TPT/XF-1250 LonWorks channel. The mid-terminal must be connected to workshop (facilities) earth.



**Attention:** Failing to connect mid-terminal to earth will cause networking problems in LonWorks TPT/XF-1250 channel and bad electromagnetic immunity of the device.

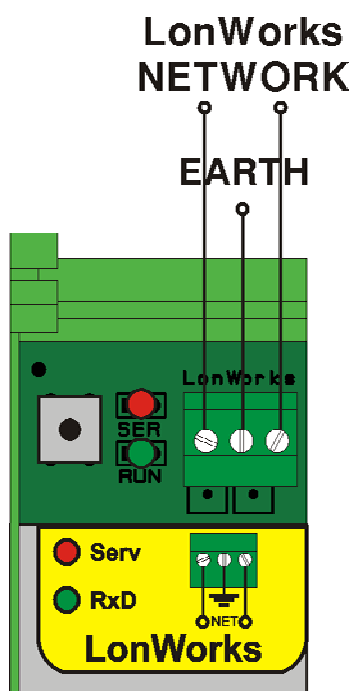

Fig. 2.3

Table 2.5

Connector	Type	Description
<b>LonWorks</b> 	terminal 1.5 mm <sup>2</sup>	1, 3 – LonWorks FTT-10 or TPT/XF – 1250 network, polarity insensitive 2 - EARTH

Table 2.6

LED	Type	Description
<b>Service</b>	RED	Standard LonWorks service LED
<b>RXD</b>	GREEN	Data received from LonWorks

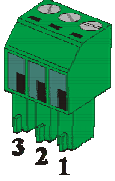

# CHAPTER 3

## PRINCIPALS OF DATA ROUTING

---

- 3.1. DP SIDE BUFFER NAMING
- 3.2. “HARD” DATA ROUTING
- 3.3. “TABLE BASED” DATA ROUTING



### 3.1. DP SIDE BUFFER NAMING



Names of buffers on ProfiBus DP side are named as they are viewed from Master side, i.e. “*Input Buffer*” is the Buffer read from Master and “*Output Buffer*” is the Buffer written from Master!

Both LonWorks and ProfiBus DP are data oriented protocols, i.e. data is exchanged between nodes, not commands.

So the main task of *DP\_LON LINK* is to transfer data from LonWorks to ProfiBus side and vice versa.

Two principals of data routing are supported by *DP\_LON LINK*:

### 3.2. “HARD” DATA ROUTING

In “Hard” routing scenario an array of 16 LonWorks byte size input variables is transferred to ProfiBus Input buffer, and 15 bytes of the ProfiBus Output buffer are transferred to 15 LonWorks byte size output variables.

THIS SPACE IS LEFT  
INTENTIONALLY BLANK

### Hard Routing Schematic

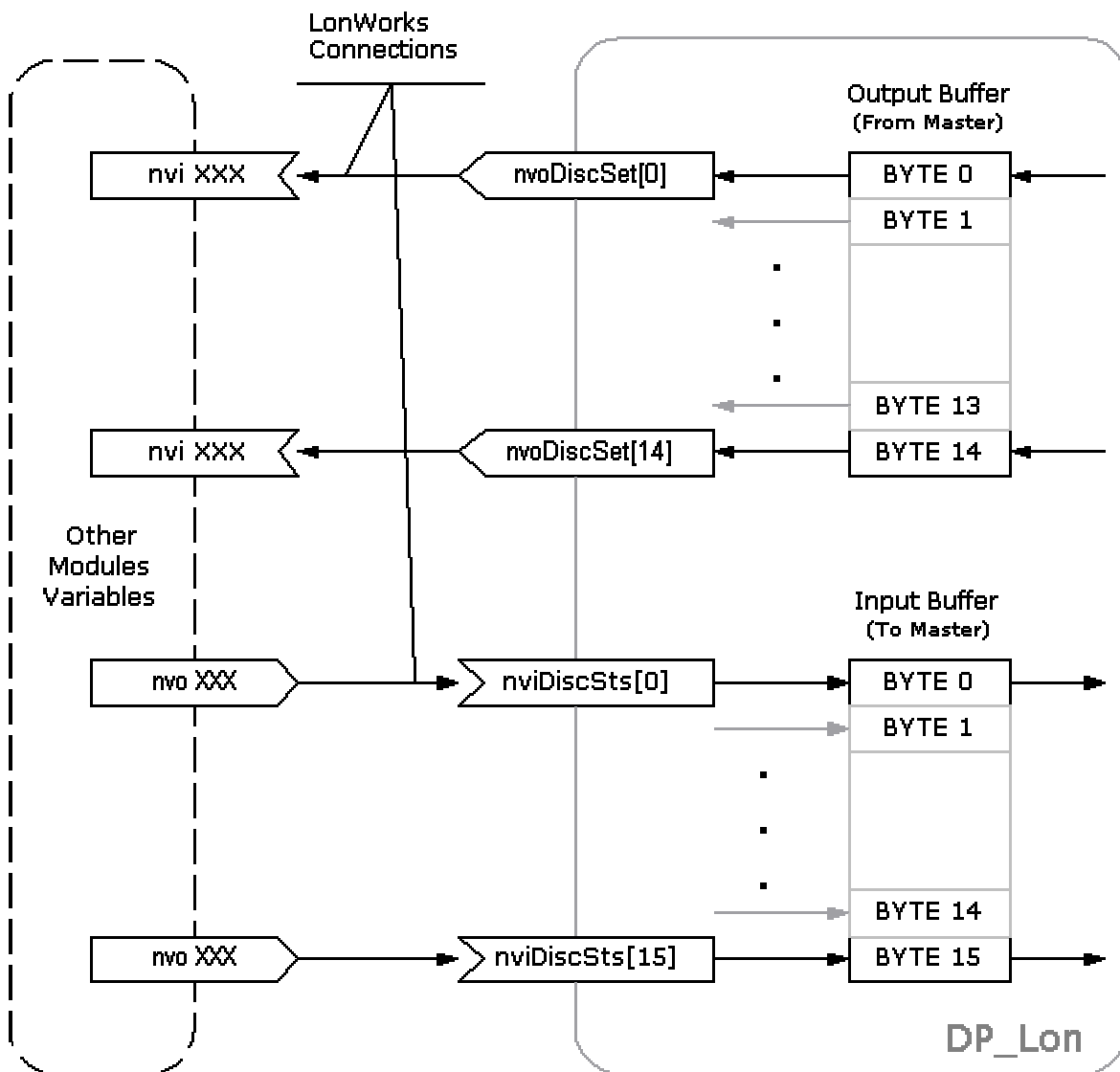

Fig. 3.1

The routing is fixed:

`nvi Disc Sts[0]` is moved in byte 0 of DP Input Buffer

`nvi Disc Sts[1]` is moved in byte 1 of DP Input Buffer

.....

`nvi Disc Sts[15]` is moved in byte 15 of DP Input Buffer



**This routing scenario has a major restriction:**

**LonWorks chip has only 15 address tables. This means that you can read no more than 16 variables from LonWorks in DP Master and control no more than 15 variables.**

### 3.3. "TABLE BASED" DATA ROUTING

In this scenario (Fig. 3.2) Routing Tables are downloaded in *DP\_LON LINK* via special plug-in from LonWorks side. These routing tables allow to avoid restriction of Neuron Chip.

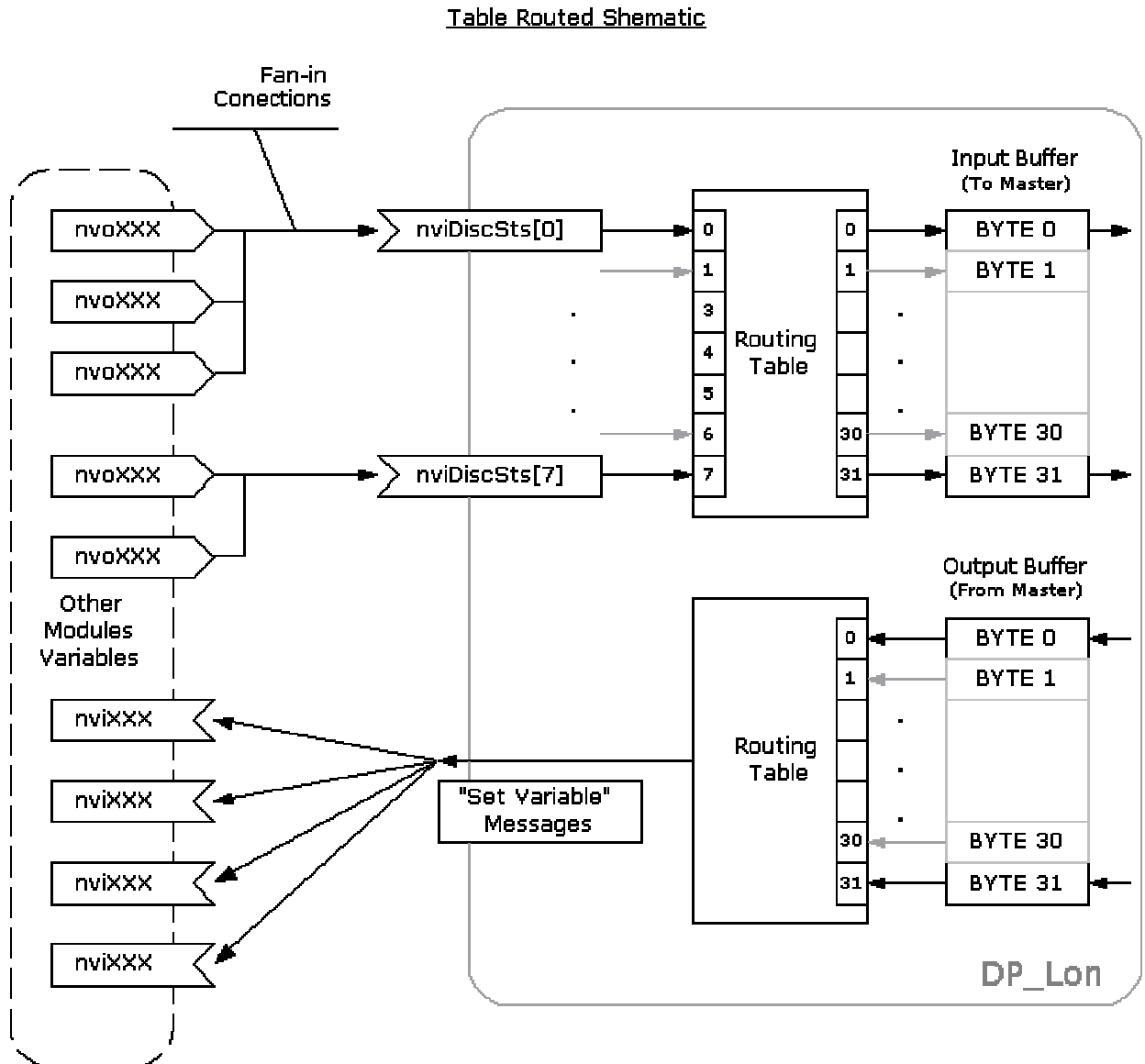

Fig. 3.2

Using this routing principal, you may connect output network variables from few modules to one input variable of *DP\_LON LINK*.

*DP\_LON LINK* doesn't use output variables to control other nodes, but explicit messages, thus avoiding using many address tables.





# CHAPTER 4

## KEYBOARD AND LCD DISPLAY

---

### 4.1. KEYBOARD AND LCD BASICS

4.1.1.  Button

4.1.2.  And  Buttons

4.1.3.  And  Buttons

### 4.2. DISPLAY AFTER POWER UP

### 4.3. CHANGING MAIN MENU, USING BUTTON

### 4.4. USING AND TO CHANGE SUBMENU

4.4.1 LonWorks Menu & Submenus

4.4.1.1. Neuron ID

4.4.1.2. Ver/Transceiver type/Subnet/Node

4.4.2. ProfiBus Menu & Submenus

4.4.2.1. ProfiBus Address Submenu

4.4.2.2. DP Control/Baudrate Submenu

4.4.3. Input Data Menu

4.4.4. Output Data Menu

#### **4.5. CONFIGURING PROFIBUS SIDE PARAMETERS**

4.5.1. Baudrate

4.5.2. DP Address Setting

4.5.2.1. DP Address Setting via LonWorks Configuration Tool

4.5.2.2. DP Address Setting via Keyboard

## 4.1. KEYBOARD AND LCD BASICS

Keyboard and LCD are used for local monitoring/diagnostic/DP address selection. There are 5 buttons on *DP\_LON LINK* keyboard.

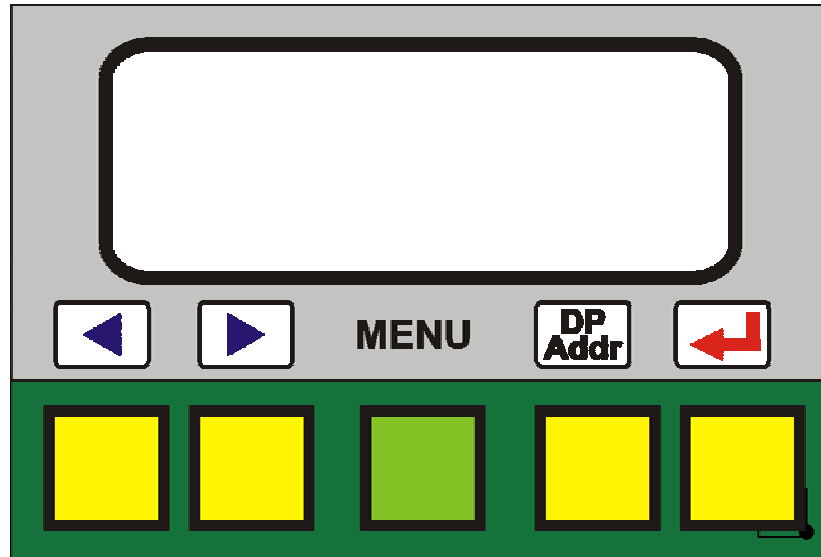

Fig. 4.1

### 4.1.1. Button

Menu button is used to browse through four main menus of *DP\_LON LINK*:

- LonWorks Menu
- ProfiBus Menu
- Input Data (ProfiBus Side)
- Output Data (ProfiBus Side)

### 4.1.2. And Buttons

These buttons are used to browse in submenus, inside selected main menu.

### 4.1.3. And Buttons

These buttons are used to change ProfiBus DP address of the device.

## 4.2. DISPLAY AFTER POWER UP

After Power Up LCD Display shows type of the Device and ProfiBus side firmware revision.

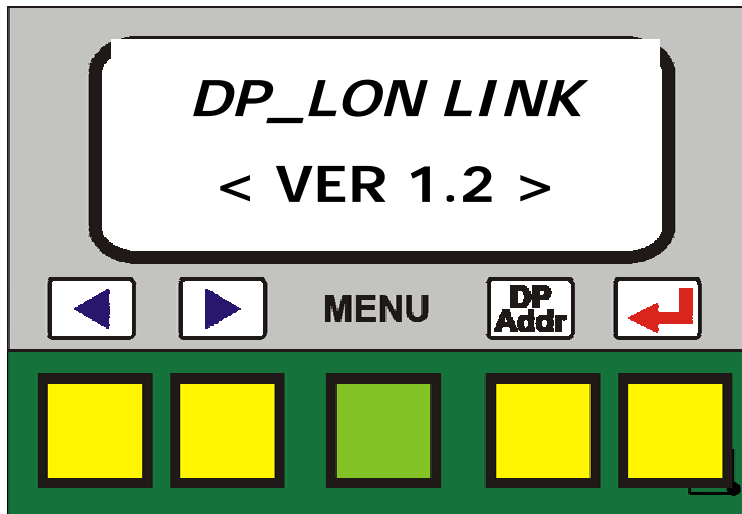

## 4.3. CHANGING MAIN MENU, USING MENU BUTTON

Each time you press MENU button, Display shows you next Main Menu, even if you are in some submenu.

There are 4 main menus:

- LonWorks menu – for diagnostic/troubleshooting of LonWorks side
- ProfiBus menu – for diagnostic/troubleshooting of ProfiBus side
- Input Data – for viewing the input data buffer (data read) of ProfiBus Master
- Output Data – for viewing the output data buffer (data written) of ProfiBus Master

**THIS SPACE IS LEFT  
INTENTIONALLY BLANK**

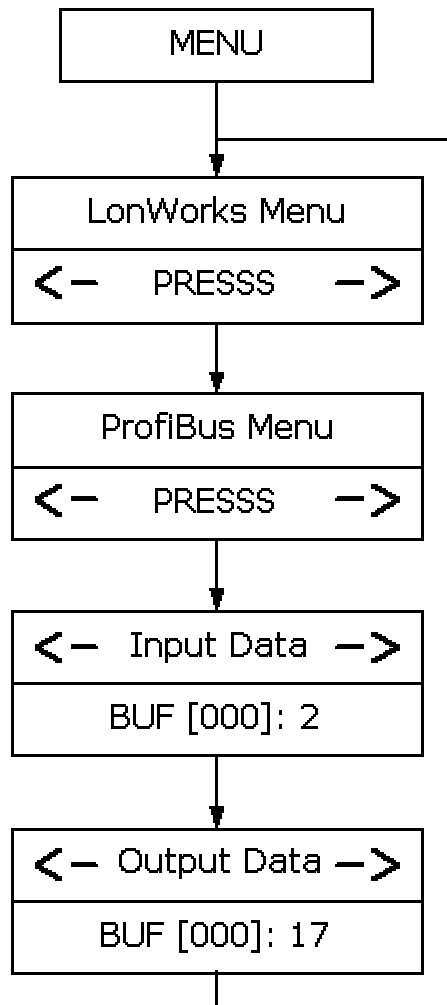

#### 4.4. USING ◀ AND ▶ TO CHANGE SUBMENU

When you are in some main menu, you may browse in it's submenus, pressing ◀ or ▶ buttons.

##### 4.4.1. LonWorks Menu & Submenus

Press and release MENU button, until you see "LonWorks Menu" on LCD Display. Then Press ◀ or ▶ buttons to go in it's submenus:

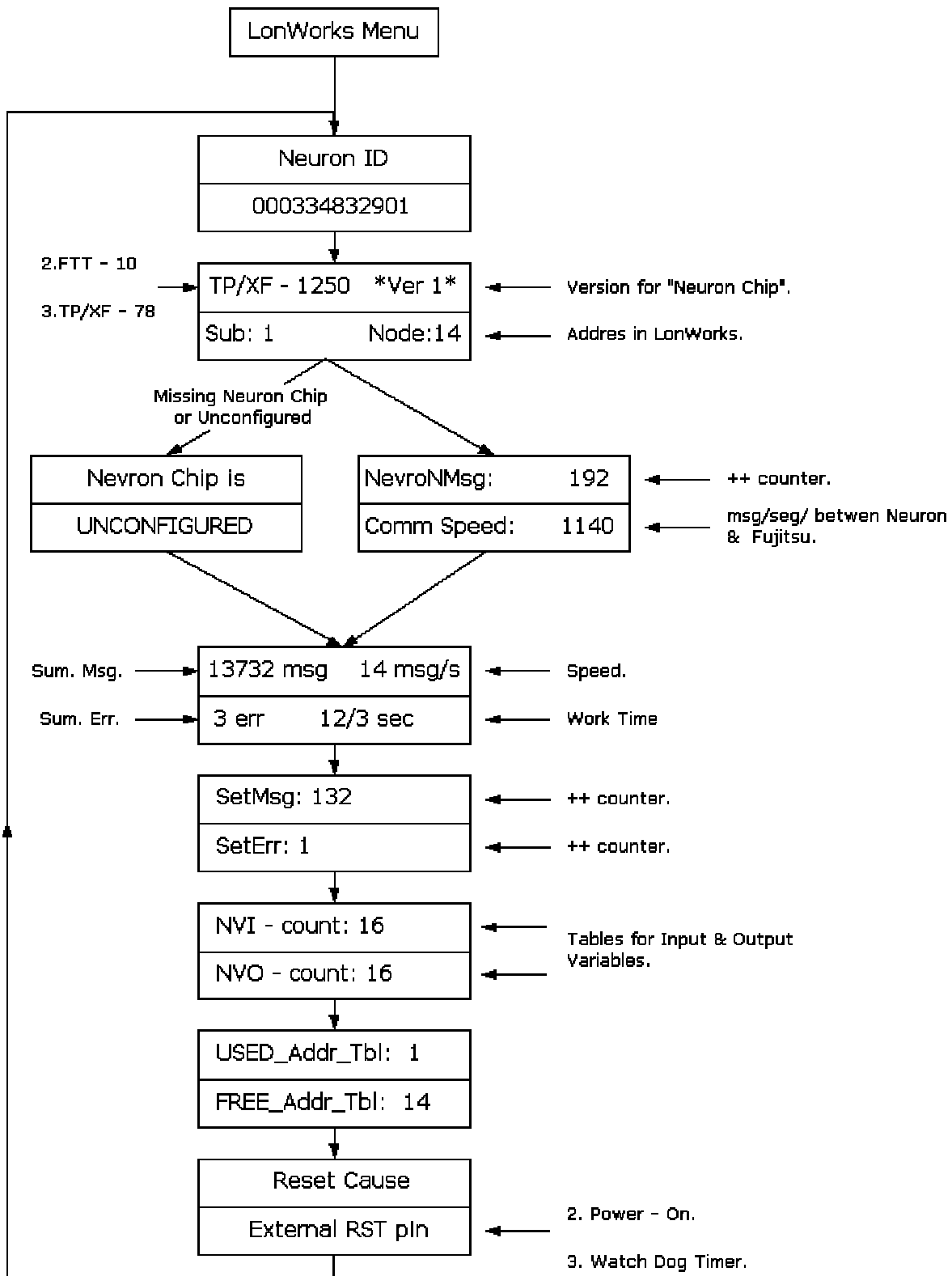

#### 4.4.1.1. Neuron ID

This submenu shows Neuron ID of the Neuron chip

#### 4.4.1.2. Ver/Transceiver type/Subnet/Node

This submenu shows revision of LonWorks side firmware, transceiver type installed (FTT-10 or TPT/XF-1250 or TPT/XF-78) and subnet /node ID/, configured by configuration tool.



All other submenus are for maintenance only.

#### 4.4.2. ProfiBus Menu & Submenus

Press and release **MENU** button, until you see “ProfiBus Menu” on LCD. Then use or buttons to browse in submenus:

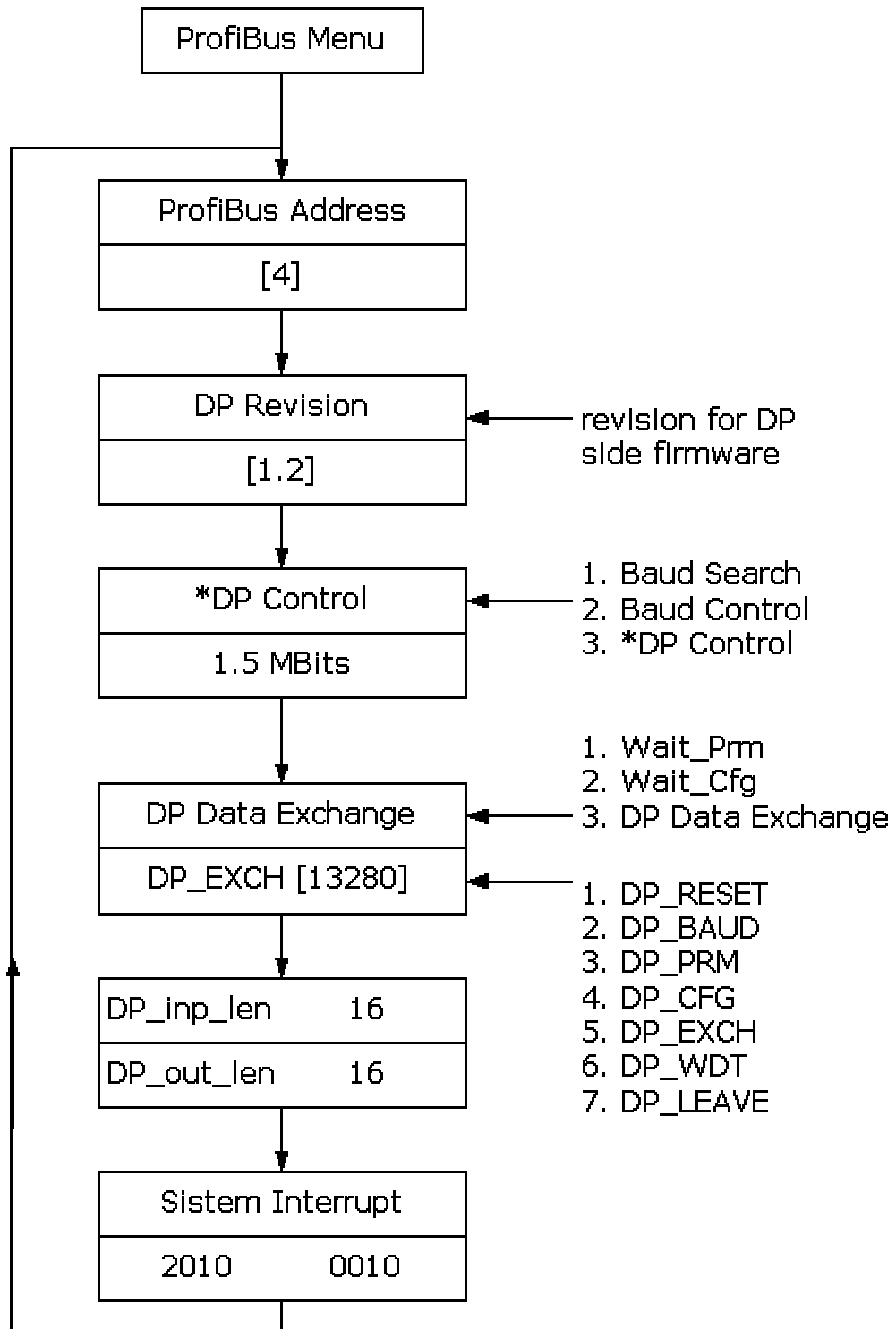

#### 4.4.2.1. ProfiBus Address Submenu

DP address (1-125) of the device is displayed.

#### 4.4.2.2. DP Control/Baudrate Submenu



This submenu shows DP Baud search status.

- Baud Search – Gateway is waiting for valid messages on ProfiBus DP network.
- Baud Control – Gateway is found valid packets and has detected baudrate, but master doesn't communicates with it.
- \*DP Control – normal operation. Gateway has found valid packets and is configured by Master.





All others submenus are for troubleshooting only.

#### 4.4.3. Input Data Menu

Press and release  button, until you see “Input Data” on the LCD display. Then use  or  buttons to browse values in Input Buffer (buffer, which is read by Master).

#### 4.4.4. Output Data Menu

Press and release  button, until you see “Output Data” on the LCD display. Then use  or  buttons to browse values in Output Buffer (buffer, which is written by Master).

### 4.5. CONFIGURING PROFIBUS SIDE PARAMETERS

#### 4.5.1. Baudrate







*DP\_LON LINK* Gateway has “Auto baud rate” functionality, so programming of the baudrate is not required.

#### 4.5.2. DP Address Setting

##### 4.5.2.1. DP Address Setting via LonWorks Configuration Tool

You may select device's DP Address in the plug-in for *DP\_LON LINK*.

##### 4.5.2.2. DP Address Setting via Keyboard

- Press  button, until you see “ProfiBus Menu” on the LCD display.
- Press  or  buttons until you see “ProfiBus Address” on the LCD display.
- Press  button to change the number on the second row of the LCD display. Note that  button only increments the address and has auto acceleration functionality (i.e. if you keep pressed the button, the speed of incrementing will increase).
- When you reach the desired address, press  button to enter the new address FLASH.



# CHAPTER 5

## GSD FILE

---



GSD file is Electronic datasheet description. This file is imported by ProfiBus configuration tools. Bellow is listed GSD file for **DP\_LON LINK** device. This file is supplied with each **DP\_LON LINK** Gateway.

```
=====
; GSD-File for PROFIBUS-DP-SLAVE  Industrial Software LTD.
; Sync_supp, Freeze_supp, 12 MBit/s
=====
; Date   : 30.05.2003
; File   : DP_LON.GSD
=====
;
#Profibus_DP
;
GSD_Revision      = 1
Vendor_Name       = "Industrial Software LTD."
Model_Name        = "DP/Lon Link"
Revision          = "A.1"
Ident_Number      = 0x06F1
Protocol_Ident    = 0
Station_Type      = 0
Hardware_Release  = "H.1"
Software_Release  = "1.2"
;
Bitmap_Device="DP_LON_N"
Bitmap_SF="DP_LON_S"
;
OrderNumber       = "6ES7 222 AS DP LON"
;
9.6_supp          = 1
19.2_supp         = 1
93.75_supp        = 1
187.5_supp        = 1
500_supp          = 1
1.5M_supp         = 1
3M_supp           = 1
6M_supp           = 1
12M_supp          = 1
;
```

```

MaxTsdr_9.6           = 60
MaxTsdr_19.2          = 60
MaxTsdr_93.75         = 60
MaxTsdr_187.5         = 60
MaxTsdr_500           = 100
MaxTsdr_1.5M          = 150
MaxTsdr_3M            = 250
MaxTsdr_6M            = 450
MaxTsdr_12M           = 800
;
Redundancy             = 0
Repeater_Ctrl_Sig     = 0
Implementation_type    = "SPC3"                ; SPC3 ASIC used.
;
Freeze_Mode_supp      = 1
Sync_Mode_supp        = 1
Auto_Baud_supp        = 1
Set_Slave_Add_supp    = 0
User_Prm_Data_Len     = 0
Min_Slave_Intervall   = 100
Modular_Station       = 1
Max_Module             = 8
Max_Input_Len         = 128
Max_Output_Len        = 128
Max_Data_Len          = 256
Slave_Family          = 9
Max_Diag_Data_Len     = 6
;
Module                 = "2 Byte Out, 2 Byte In" 0x11,0x21
1
EndModule
;
Module                 = "4 Byte Out, 4 Byte In" 0x13,0x23
2
EndModule
;
Module                 = "8 Byte Out, 8 Byte In" 0x17,0x27
3
EndModule

```

```
;
Module          = "16 Byte Out, 16 Byte In" 0x1F,0x2F
4
EndModule
;
Module          = "32 Byte Out, 32 Byte In" 0x1F,0x1F,0x2F,0x2F
5
EndModule
;
```





## **CHAPTER 6**

# **PREPARING SIEMENS STEP7 DEVELOPMENT ENVIRONMENT FOR USING *DP\_LON LINK***

---



In order to use DP\_LON LINK with STEP7 software and Siemens PLC's follow the steps below:

- Copy files on Fig. 6.1 on your PC

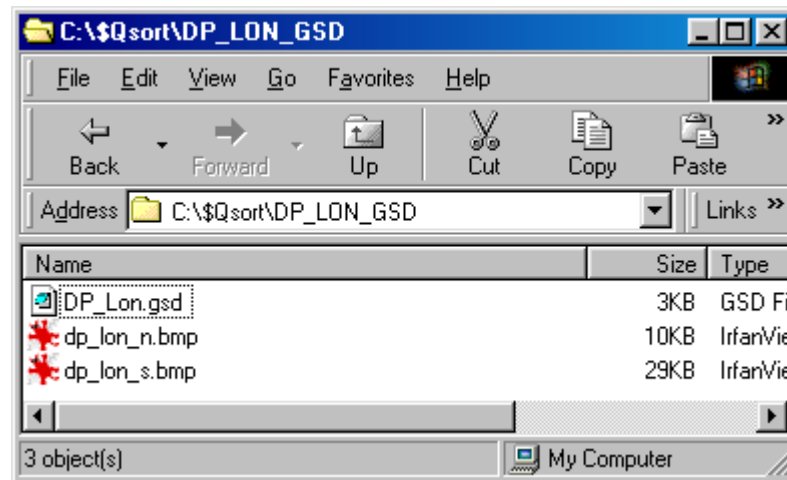

Fig. 6.1

- Run STEP7 software
- Enter "hardware" screen
- Import dp\_lon.gsd file (Fig. 6.2 and Fig. 6.3)

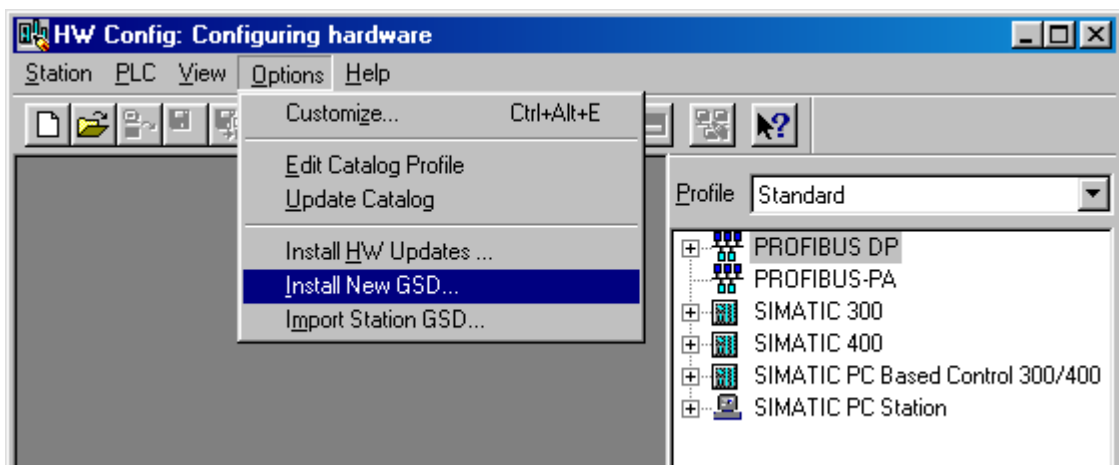

Fig. 6.2



Fig. 6.3

Now you can add DP\_LON LINK in your projects.

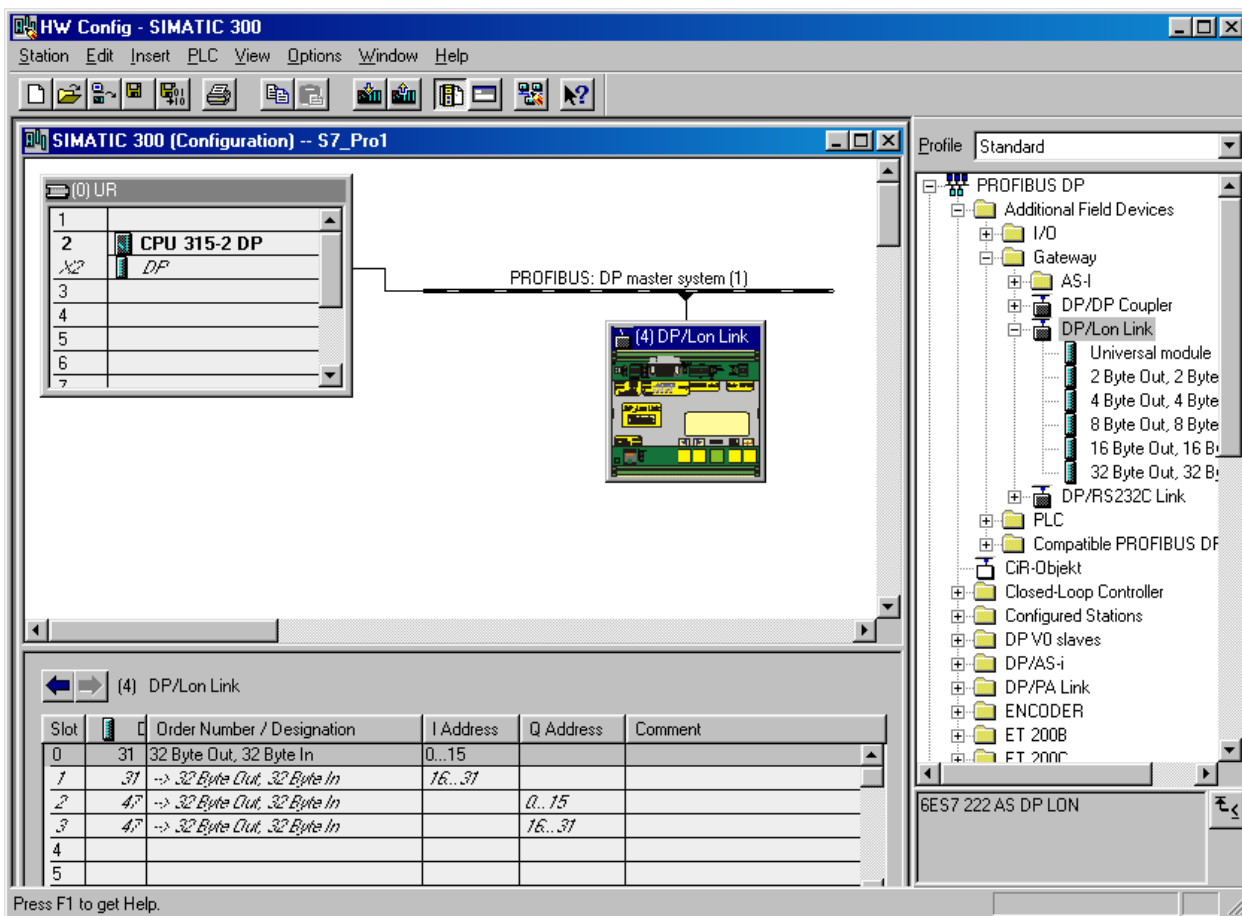

Fig. 6.4



# CHAPTER 7

## USING *DP\_LON LINK* IN CONVEYOR CONTROL SYSTEMS

---



Using *DP\_LON LINK* with RollOn configuration tool is simple and easy.  
First add a *DP\_LON LINK* device in your project.

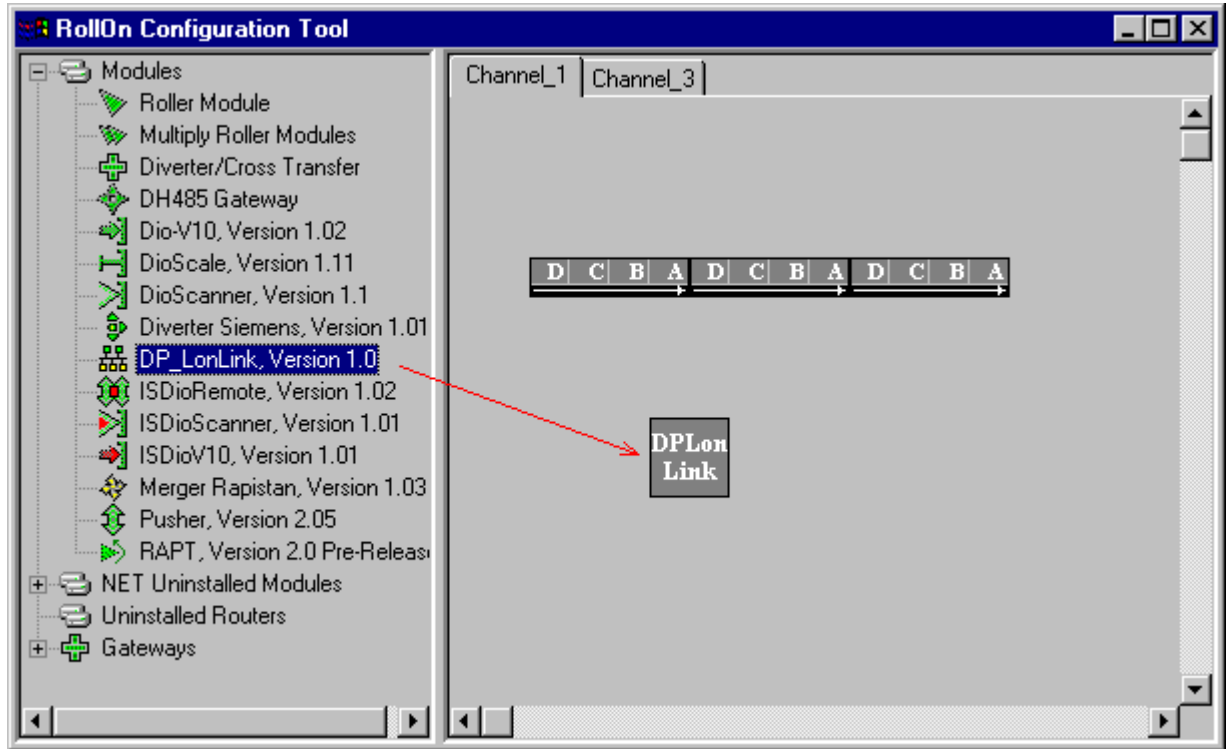

Fig. 7.1

**THIS SPACE IS LEFT  
INTENTIONALLY BLANK**

Each *DP\_LON LINK* provides 4 types of virtual devices to user:

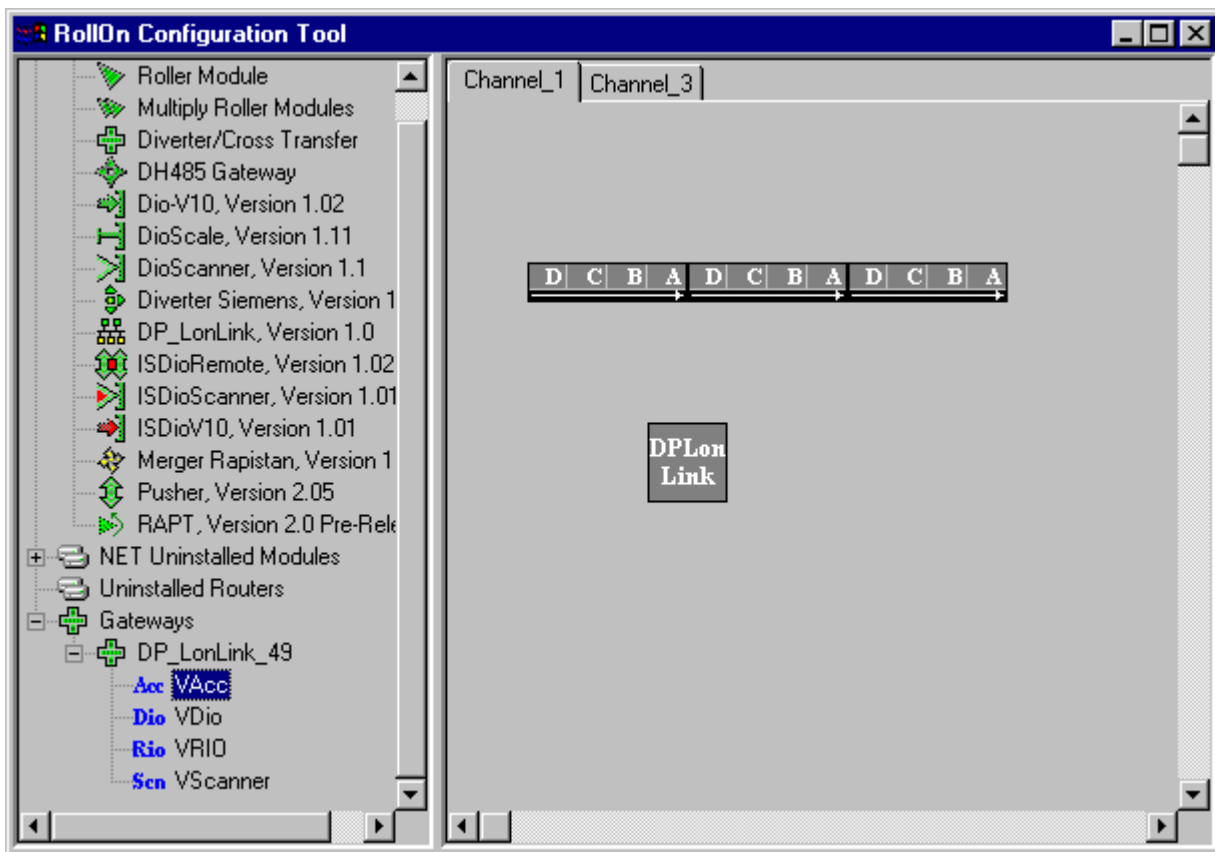

Fig. 7.2

THIS SPACE IS LEFT  
INTENTIONALLY BLANK

- *Virtual run/status pair*

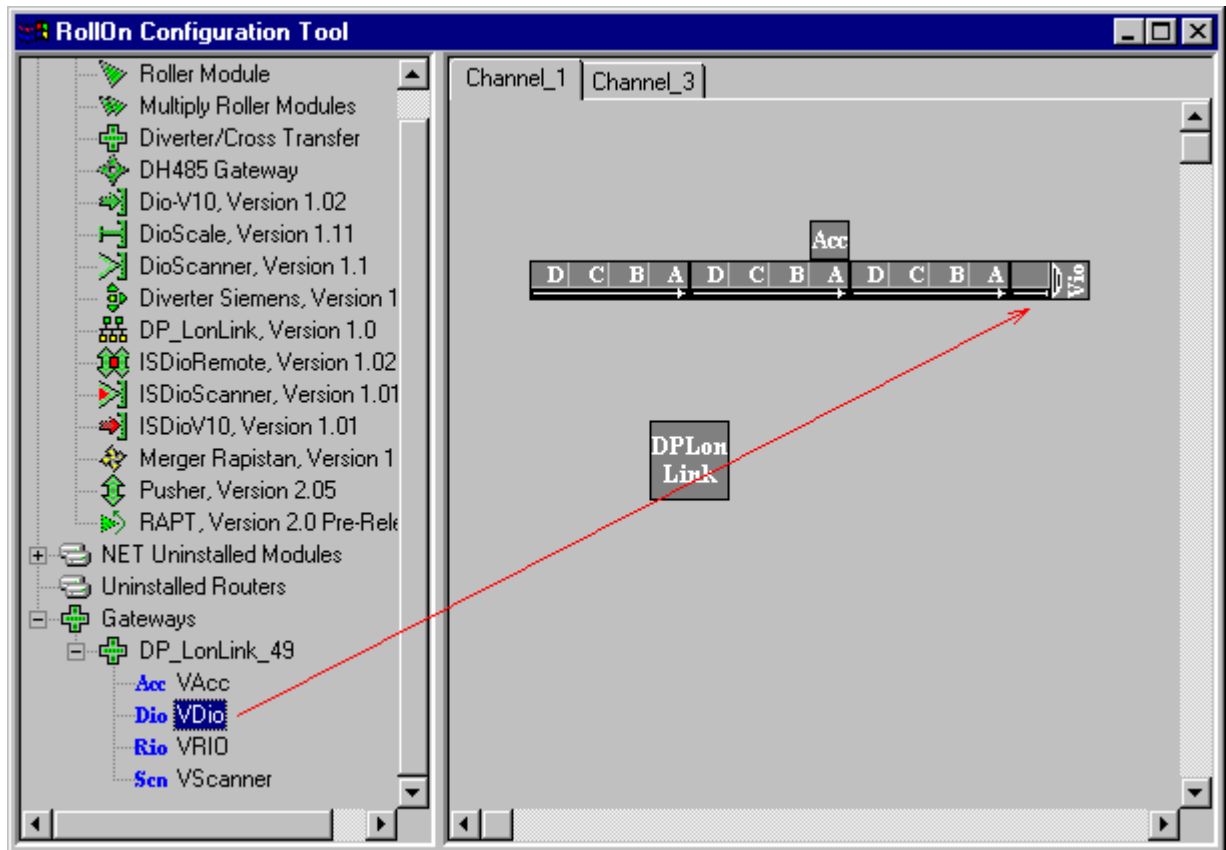

Fig. 7.3

This virtual device sends nvoSensOut variable in one byte of the Master's Input buffer and uses 1 byte of Master's Output buffer to control nviSensIn variable of the same zone. This virtual device replaces DIO functionality.

Virtual **Run / Status** Pair

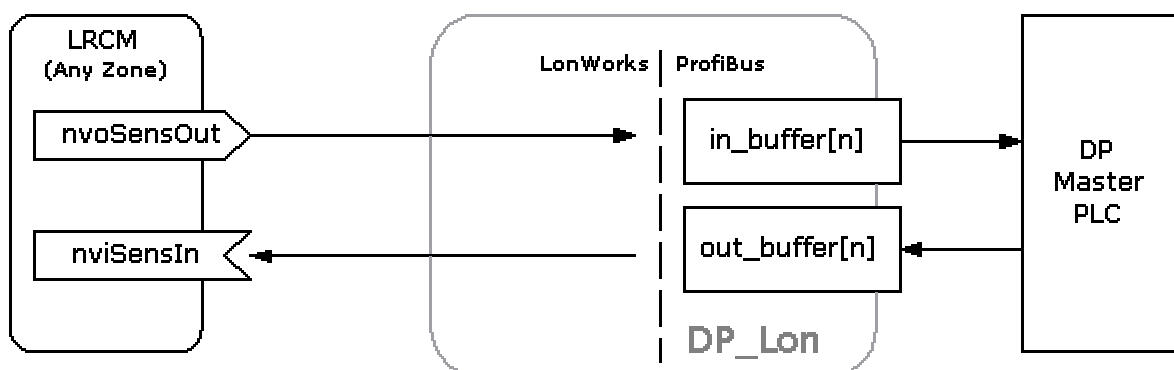

Fig. 7.4

- *Virtual accumulate/status pair*

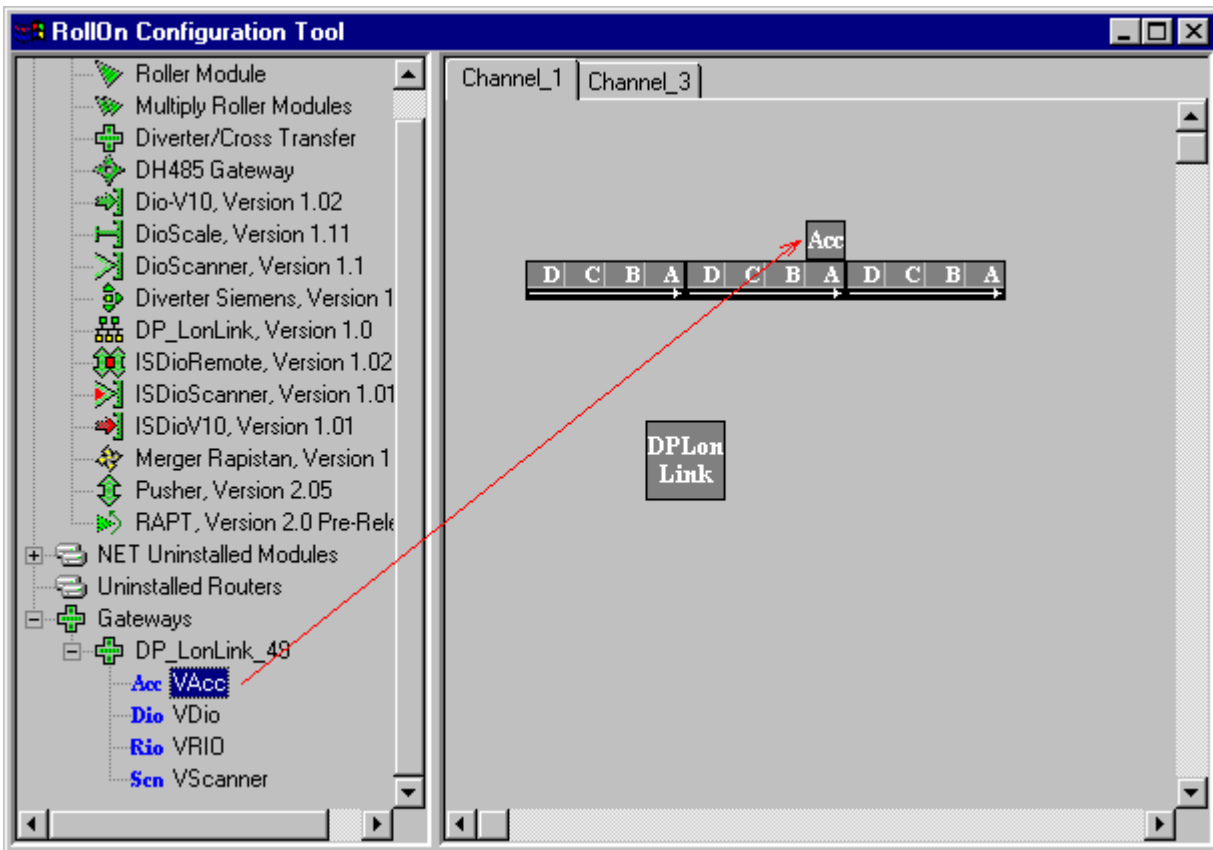

Fig. 7.5

This virtual device sends nvoSensOut variable in one byte of the Master's Input buffer and uses 1 byte of Master's Output buffer to control nviAccJog variable of the same zone. This virtual device replaces "Scale" device functionality.

**Virtual Accumulation / Status Pair**

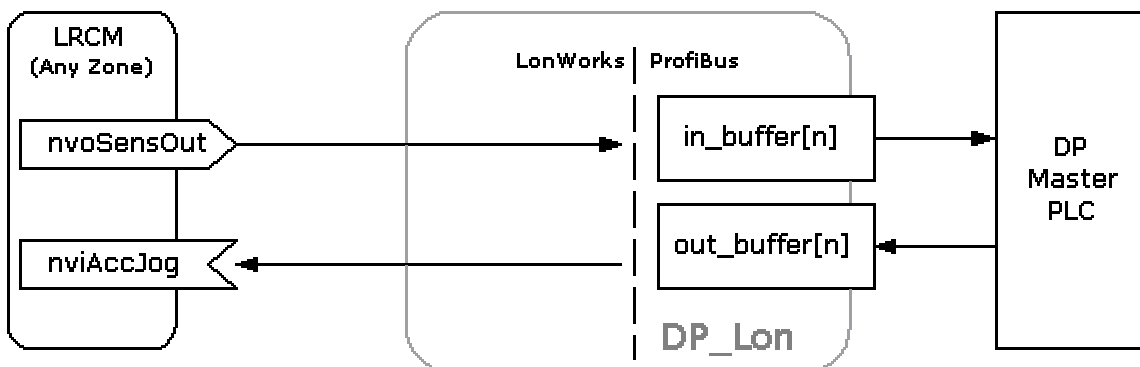

Fig. 7.6

- *Virtual scanner*

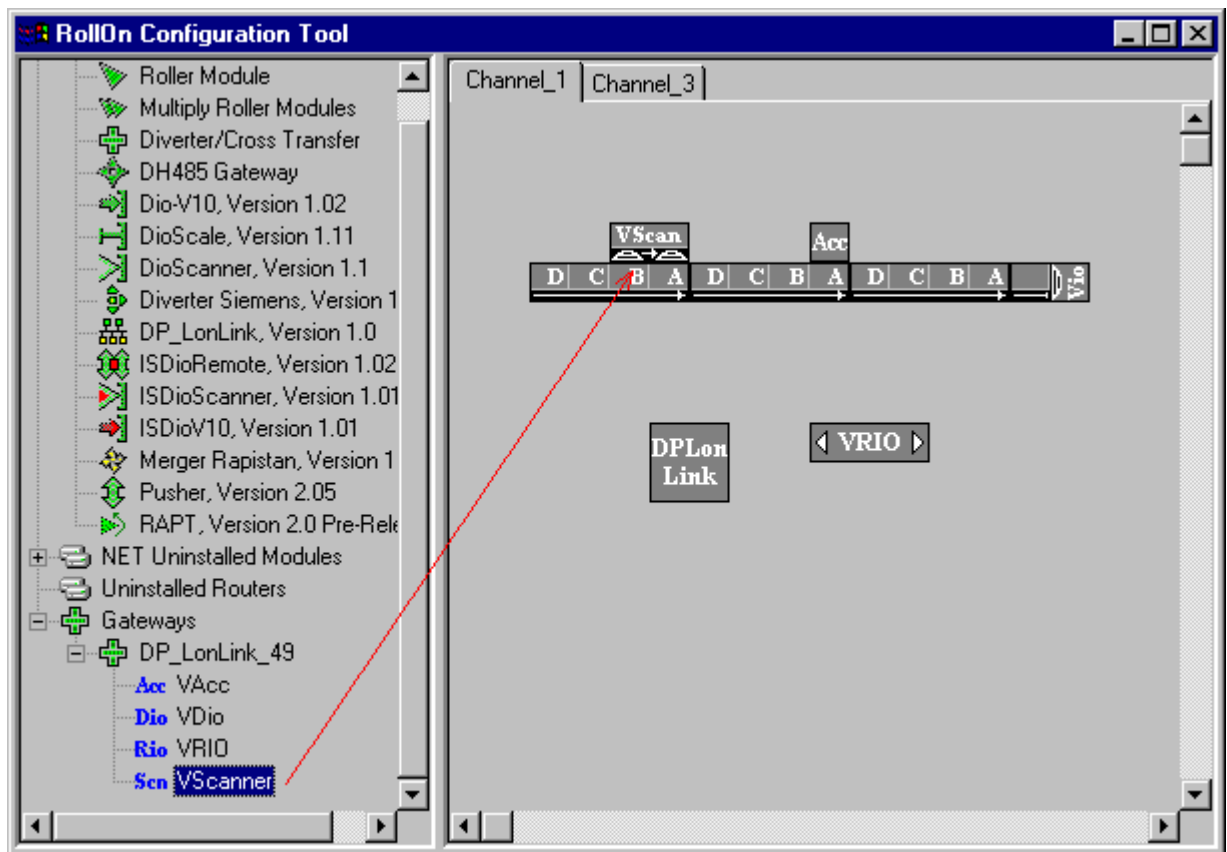

Fig. 7.7

This virtual device uses same connectivity as “Scanner” device. It connects nvoSensOut variables for zones A and B of an LRCM and sends them in 2 bytes of Master’s Input buffer. It also connects 2 bytes of Master’s Output buffer to control nviAccJog variables of A and B zones.

**THIS SPACE IS LEFT  
INTENTIONALLY BLANK**

Virtual Scanner

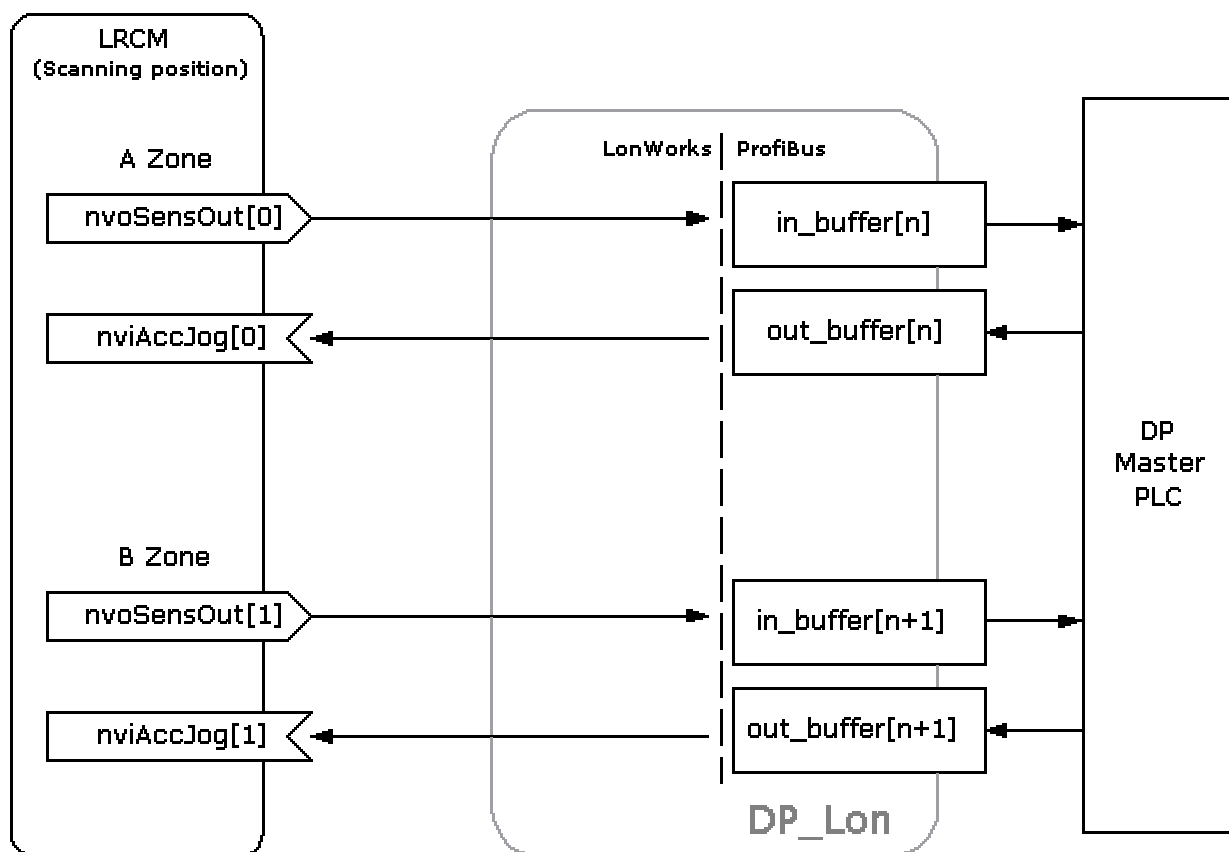

Fig. 7.8

THIS SPACE IS LEFT  
INTENTIONALLY BLANK

- *Virtual RIO*

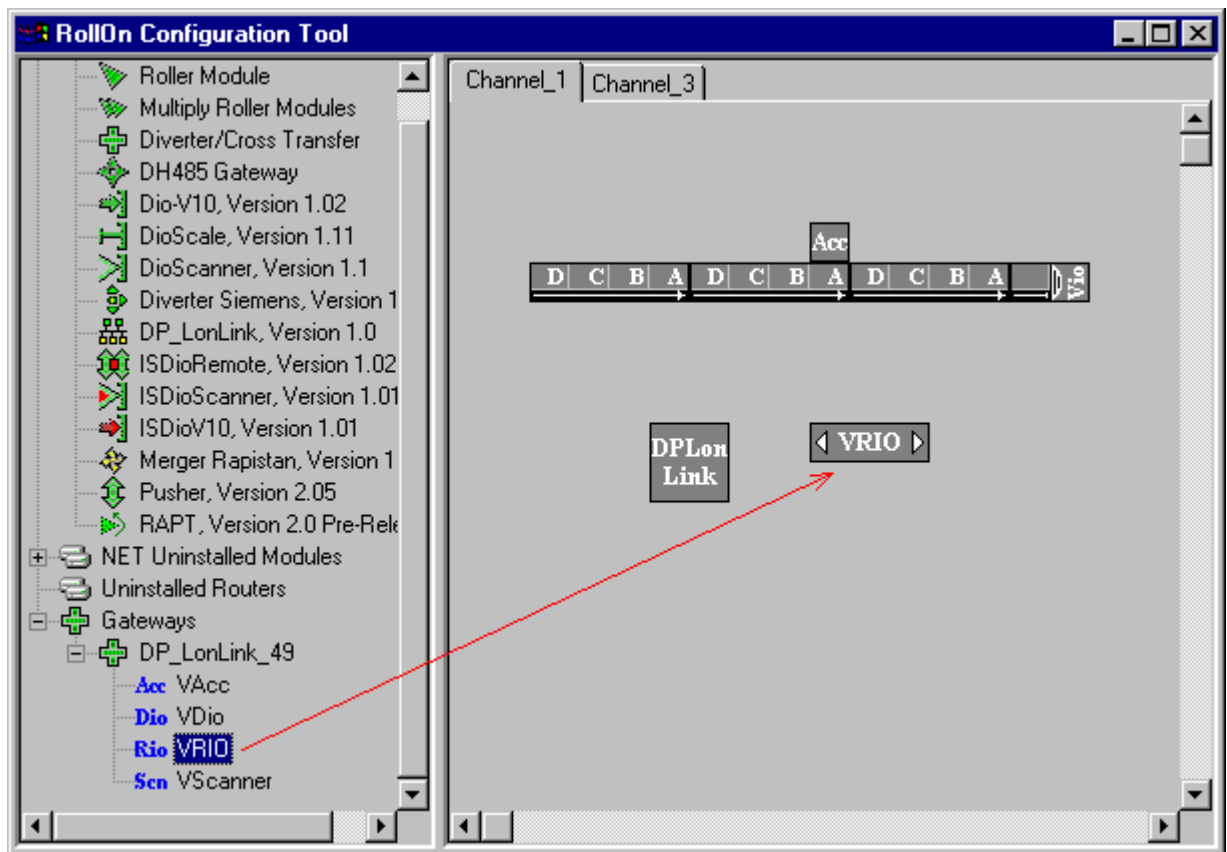

Fig. 7.9

This virtual device reads and controls 4 input/4 output variables of KID Neuro the same way as RIO module does.

**THIS SPACE IS LEFT  
INTENTIONALLY BLANK**

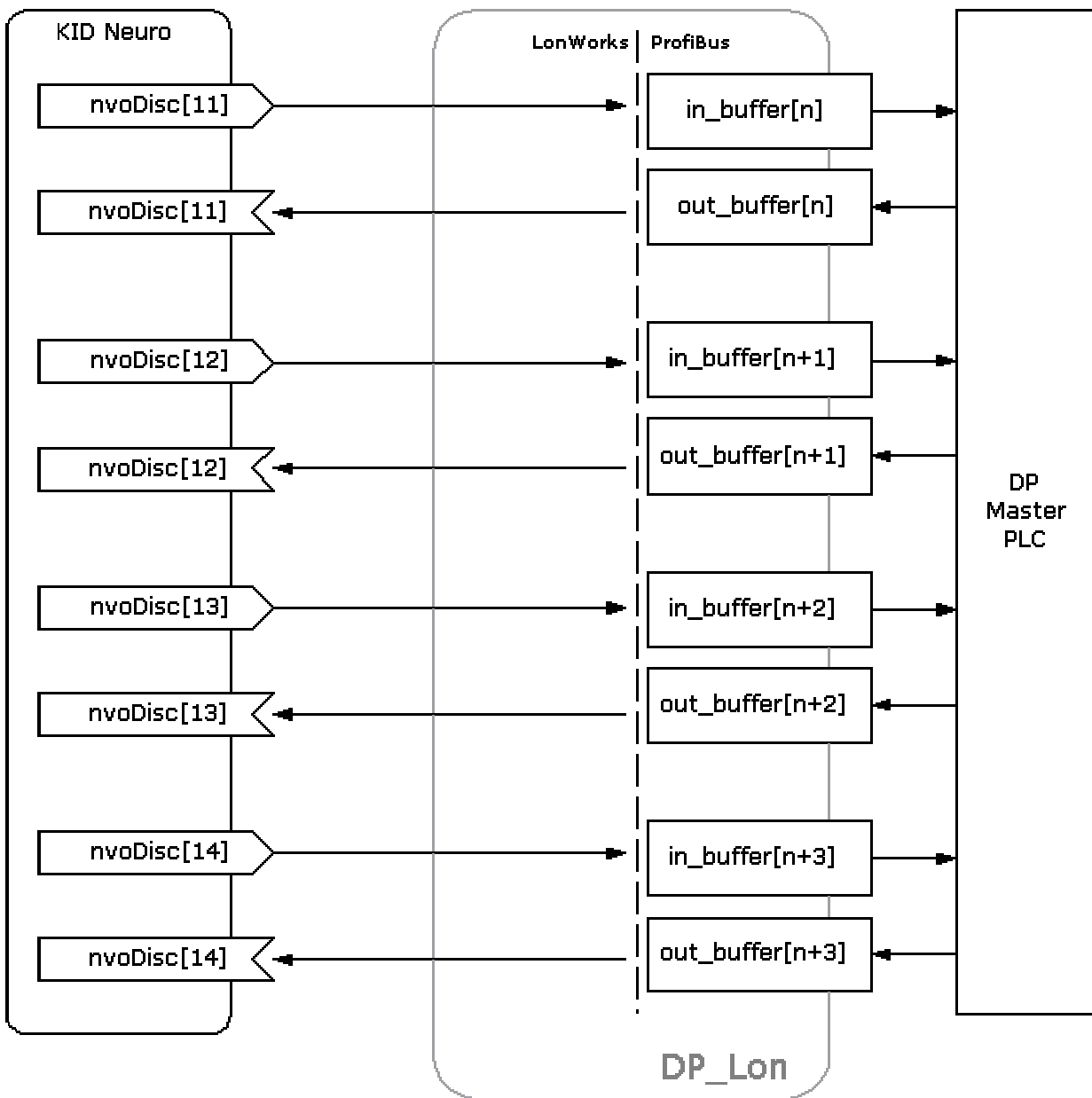

Fig. 7.10

You may mix type of virtual devices you use with a gateway.

For example you may use 5 virtual RIO, 2 virtual DIO and 5 virtual Scanners.

Always take in account, that **DP\_LON LINK** transfers up to 32 variables to Master and 32 variables from Master.

You may remove individually each virtual device or remove the Gateway at all.

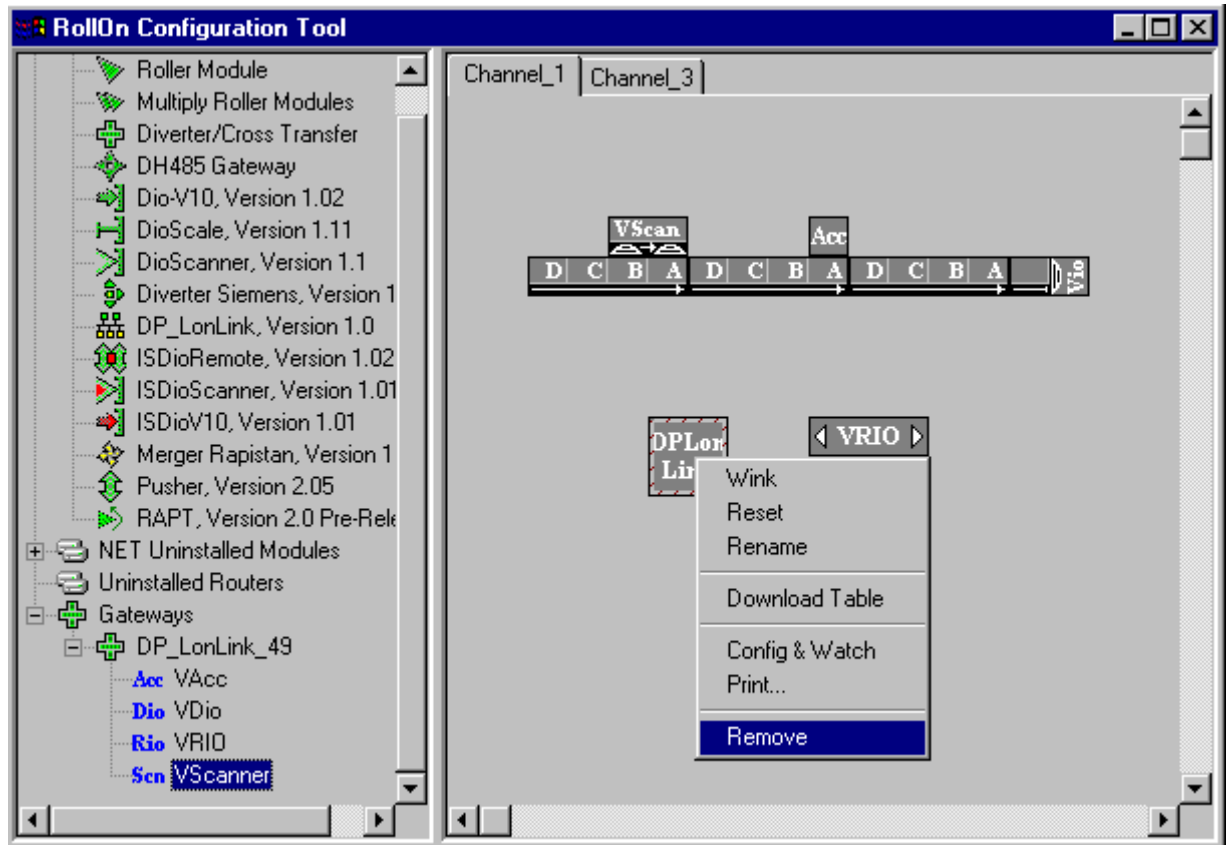

Fig. 7.11

When Gateway is removed all associated virtual devices are removed also.

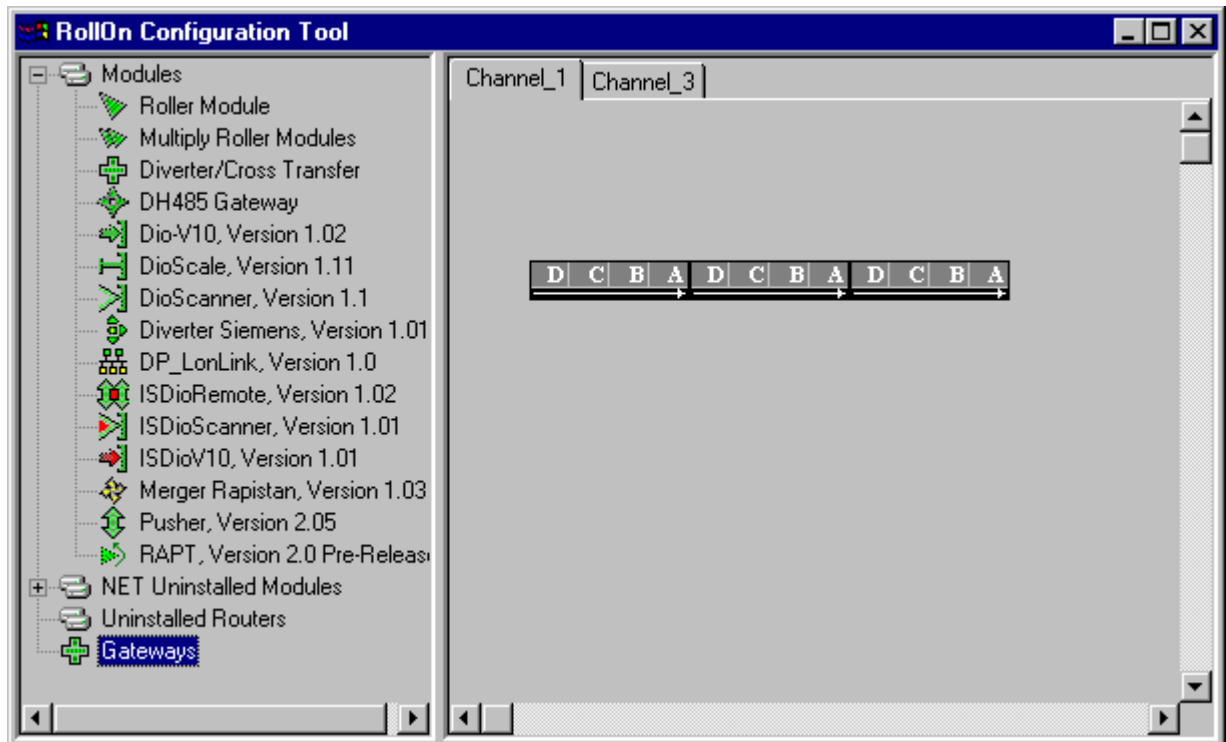

Fig. 7.12



