



CANopen DIGITAL INPUT/OUTPUT MODULE DIO88 User's Manual

Version 1



Revision December 2002

Industrial Software Co.

45, Lokorska Str.

1225, Sofia, BULGARIA

Phone/Fax: (+359 2) 975 11 80/1/2/3/4

E-mail: indsoft@einet.bg

www.indsoft.bg

Contents

CHAPTER 1. CANopen DIGITAL INPUT/OUTPUT MODULE (DIO88) SPECIFICATIONS

1.1.	DIO88 TECHNICAL CHARACTERISTICS.....	1-1
1.2.	DIO88 GENERAL DESCRIPTION.....	1-2
1.2.1.	CANopen Interface.....	1-3
1.2.2.	CANopen and Application Status LED Indicators	1-3
1.2.3.	Power Supply	1-4
1.2.4.	Power LED Indicator	1-4
1.2.5.	Installation Push Button.....	1-5
1.2.6.	Node ID HEX Switches.....	1-5
1.2.7.	Baud rate or Configuration HEX Switch	1-5
1.3.	DIO88 DIMENSIONS AND MECHANICAL INSTALLATION.....	1-5

CHAPTER 2. DIO88' CONNECTIONS

2.1.	DIO88 POWER SUPPLY.....	2-1
2.2.	CRCM CANopen INTERFACE CONNECTOR.....	2-1
2.3.	DIO88 DIGITAL I/O TERMINALS AND CONNECTIONS	2-3
2.3.1.	Connection of Digital Inputs	2-3
2.3.1.1.	Circuit for commutation of “-”with dry contact.....	2-4
2.3.1.2.	Circuit for connection with NPN transistor.....	2-4
2.3.1.3.	Mixed connection with common +	2-4
2.3.1.4.	Circuit for commutation of “+”with dry contact.....	2-4
2.3.1.5.	Circuit for connection with PNP transistor.....	2-5
2.3.1.6.	Mixed connection with common -	2-5
2.3.2.	Connection of Digital Outputs	2-5

CHAPTER 3. USING CANopen DIO88 AS PUSHER ACTUATOR CONTROL

3.1.	GENERAL.....	3-1
3.2.	CRCM CONNECTIONS TO PUSHER HARDWARE.....	3-2

3.3.	DIO88 CONNECTIONS TO PUSHER HARDWARE	3-2
3.3.1.	Actuator Control Interface.....	3-3
3.3.1.1.	Actuator with PUSH / RETRACT inputs.....	3-3
3.3.1.2.	Actuator with ACTION / DIRECTION inputs	3-3
3.3.2.	Actuator Feedback Inputs	3-4
3.3.3.	External Pushing Action Request	3-4
3.3.4.	Percentage Divert Input Interface.....	3-4
3.3.5.	Error Report Output Interface.....	3-4

CHAPTER 4. USING CANopen DIO88 AS GENERAL PURPOSE GENERIC I/O MODULE

CHAPTER 5. DIO88 ELECTRONIC DATA SHEET

5.1.	GENERAL.....	5-1
5.2.	DIO88 EDS FILE	5-1



CHAPTER 1

CANopen DIGITAL INPUT/OUTPUT MODULE (DIO88) SPECIFICATIONS

- 1.1. DIO88 TECHNICAL CHARACTERISTICS
- 1.2. DIO88 GENERAL DESCRIPTION
 - 1.2.1. CANopen Interface
 - 1.2.2. CANopen and Application Status LED Indicators
 - 1.2.3. Power Supply
 - 1.2.4. Power LED Indicator
 - 1.2.5. Installation Push Button
 - 1.2.6. Node ID HEX Switches
 - 1.2.7. Baud rate or Configuration HEX Switch
- 1.3. DIO88 DIMENSIONS AND MECHANICAL INSTALLATION

1.1. DIO88 TECHNICAL CHARACTERISTICS

Table1.1

PARAMETER	RANGE (SPEC'S) DESCRIPTION
Power Supply Voltage	
- Nominal power supply voltage	24 V DC (rectified, filtered, with maximum ripples 300 mV peak-to-peak)
- Power supply voltage range	18 to 30 V DC
- Current consumption	50 to 120 mA
- Connector	Terminal 1.5 mm ²
24-V Digital Inputs	
- Number of inputs	8
- Nominal input voltage	24 V DC
- Input voltage range	Up to 30 V DC
- Input current	6 to 30 mA (according to IEC 1131)
- Logic 0	0 to 5 V DC (according to IEC 1131)
- Logic 1	11 to 35 V DC (according to IEC 1131)
- Connector	Terminal 1.5 mm ²
NPN Open Collector Digital Outputs	
- Number of outputs	8
- Nominal supply voltage	24 V DC
- Switching voltage	10 to 30 V DC
- Max switching current	0.1 A
- Connector	Terminal 1.5 mm ²
Miscellaneous	
Interface	CAN, Powered, 6÷30VDC
Protection	IP20
Nominal temperature range	-20°C to 85°C
Conditions for transportation and storage	Temperature: -20°C to 85°C Humidity: up to 90% RH FRAGILE!
Electromagnetic compatibility	IEC 1131 – 2, IEC 801 – Level 2
Dimensions	109mm x 90mm x 48mm
Mounting	DIN Rail
Weight	about 200g

1.2. DIO88 GENERAL DESCRIPTION

The Front Panel of the DIO88 is shown in Fig. 1.1.

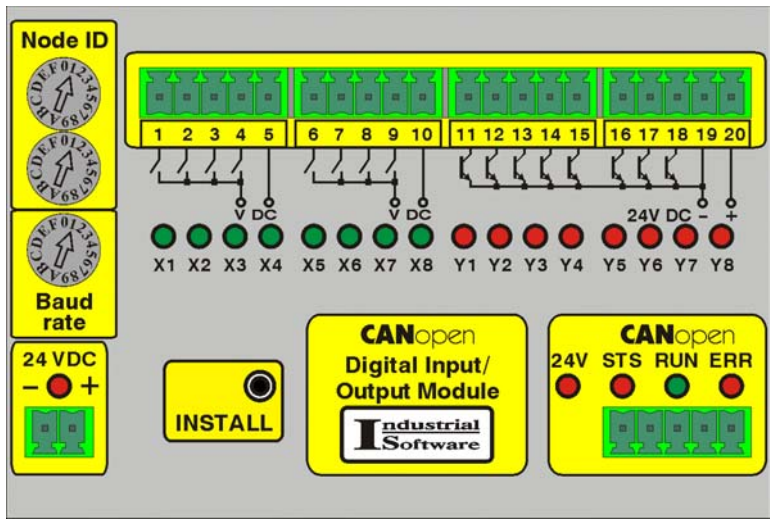

Fig. 1.1

Each DIO88 provides following features:

- Connector for 24V DC power supply.
- Power LED indicator.
- Install Button.
- Connector for CAN interface.
- 4 CAN status LED indicators.
- 2 five-pin connectors for digital outputs.
- 8 LED indicators for digital outputs.
- 2 five-pin connectors for digital inputs.
- 8 LED indicators for digital inputs.
- 2 Node ID HEX switches
- 1 Baudrate HEX switch

The above features are illustrated in the respective group fields on the Front Panel shown in Fig. 1.2.

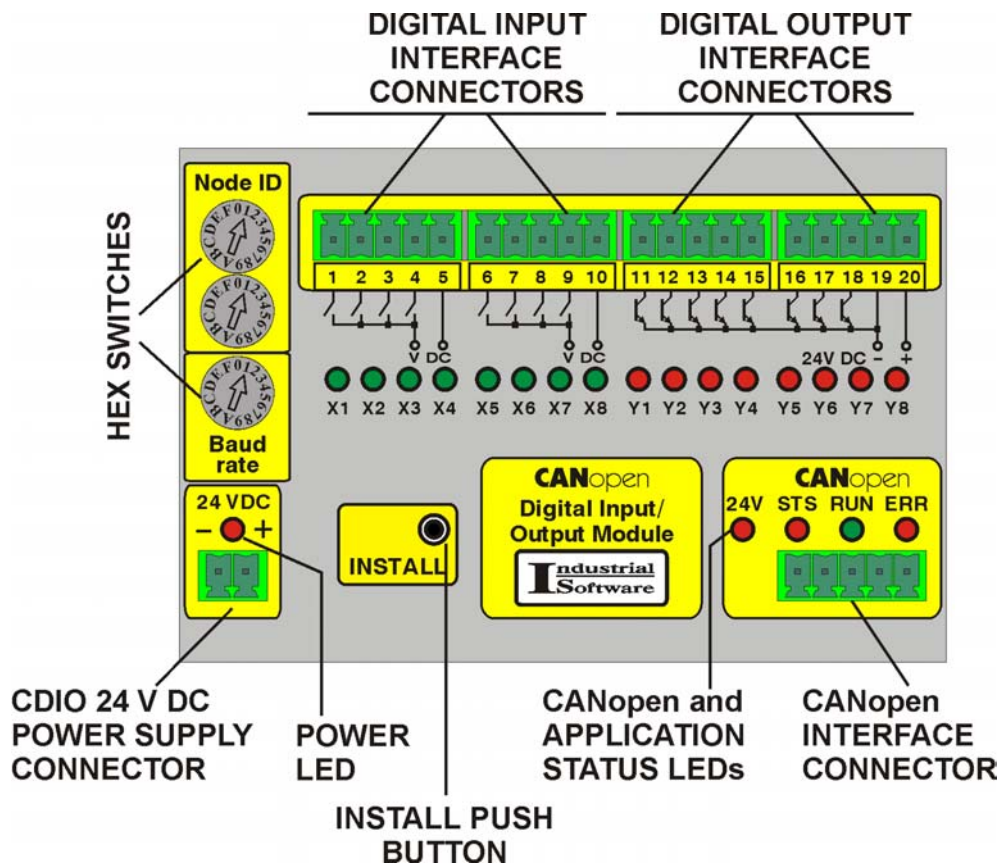
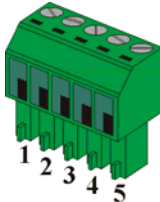

Fig. 1.2

1.2.1. CANopen Interface

The 5-pin connector provides terminals for CAN interface in accordance with CiA Draft Recommendation DR-303-1.

For more details you may refer to Table below.

CANopen Connection	Pin No	Function
	1	CAN_GND CAN Ground/0V/V-
	2	CAN_L bus line (dominant low)
	3	Optional CAN Shield
	4	CAN_H bus line (dominant high)
	5	(CAN_V+) External positive supply for galvanic isolation (6-30VDC)**

1.2.2. CANopen and Application Status LED Indicators

Each CRCM has following diagnostic LED's:

- 2 CANopen Status LED's

These 2 LEDs are specific and report the CANopen state of the device (i.e. of CRCM) as described in CiA document DR-303-3 – “CANopen Indicator Specification”. These two LED's are labeled as “**RUN**” and “**ERR**”.

RUN LED is **Green**

ERR LED is **Red**

RUN *Blinking* –The Device is in “Pre-Operational Mode”

RUN *On* –The Device is in “Operational Mode”

RUN *Single Flash, then Off* – The Device Executes “Stopped Mode”

ERR *Off* – No Error

ERR *Single Flash* – At least one of error counters of the CAN controller has reached or exceeded the warning level

ERR *On* – The CAN controller is Bus Off

- **Application Status LED**

This LED is **Red** and is labeled as “**STS**”

It describes the application program status:

STS *On* or *Off* – The module is “Applicationless”. The User has to download valid application program to the module.

STS *Flickering* – The module has a valid and running program

- **CAN 24 VDC LED**

This LED is **Red** and is labeled as “**24V**”

It describes the power supply status of CAN Interface:

24V *On* – CAN Power supply is OK

24V *Off* – There is no power supply for CAN Interface

1.2.3. Power Supply

The power supply voltage of CRCM is 24 V DC (15 to 30 V). The module current consumption is 120 mA.

For more details you may refer to Table below.

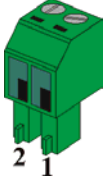
Module Power Connection	Micro Pin	Function
	1	+ Power Supply
	2	- Power Supply

1.2.4. Power LED Indicator

This LED is **Red**.

Power LED indicator is *ON* when 24 V DC power is connected properly to DIO88.

1.2.5. Installation Push Button

The Installation Push Button is used during the configuration procedures of DIO88.

1.2.6. Node ID HEX Switches

There are two HEX switches for selection of the DIO88 identification number.

The **upper** switch is for **High Node ID**

The **lower** switch is for **Low Node ID**

1.2.7. Baud rate or Configuration HEX Switch

This switch is used for DIO88 Baud rate or Configuration selection.

1.3. DIO88 DIMENSIONS AND MECHANICAL INSTALLATION

The DIO88 is assembled on a DIN rail.

The DIO88 has the following dimensions:

Width – 109 mm

Height – 90 mm

Thickness (including connectors) – 48 mm

The respective sizes of DIO88 are shown in Fig. 1.3.

The mechanical installation of DIO88 is executed in the following order:

- a.** Drill two clearance holes for mounting DIN rail.
- b.** Mount the rail.
- c.** Mount the module on the rail.

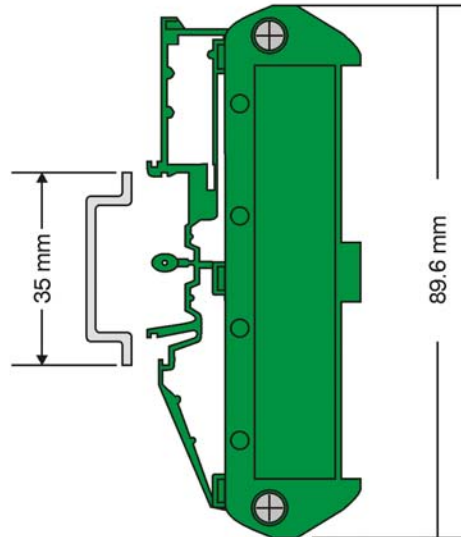
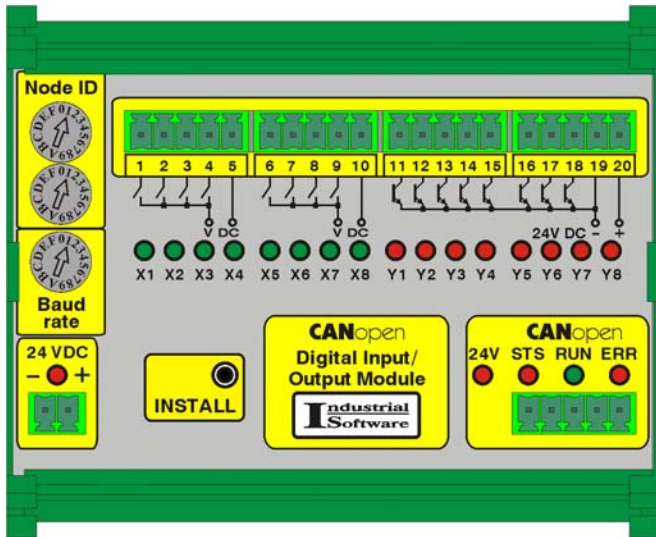
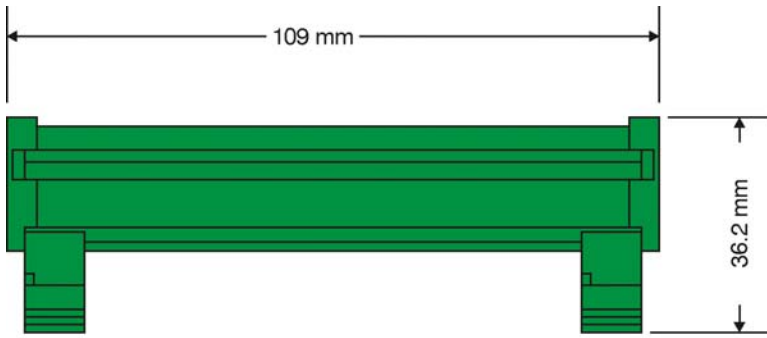

Fig. 1.3



CHAPTER 2

DIO88' CONNECTIONS

- 2.1. DIO88 POWER SUPPLY**
- 2.2. CRCM CANopen INTERFACE CONNECTOR**
- 2.3. DIO88 DIGITAL I/O TERMINALS AND CONNECTIONS**
 - 2.3.1. Connection of Digital Inputs**
 - 2.3.1.1. Circuit for commutation of “-”with dry contact
 - 2.3.1.2. Circuit for connection with NPN transistor
 - 2.3.1.3. Mixed connection with common +
 - 2.3.1.4. Circuit for commutation of “+”with dry contact
 - 2.3.1.5. Circuit for connection with PNP transistor
 - 2.3.1.6. Mixed connection with common -
 - 2.3.2. Connection of Digital Outputs**

2.1. DIO88 POWER SUPPLY

The DIO88 is powered by 24 V DC (Fig. 2.1), whereas the power supply voltage is subject to the following requirements:

- rectified;
- filtered;
- max. ripples 300 mV peak-to-peak

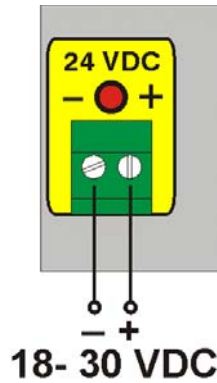

Fig. 2.1

The power supply of the DIO88 is galvanically isolated from the power supply of the processor, communications and digital parts.

Table 2.1

Connector	Type	Description
24V	terminal 1.5 mm ²	DIO88 power supply

Table 2.2

LED	Type	Description
24V	red	LED ON shows that the power supply voltage is connected; LED OFF shows the absence of power supply voltage

2.2. CRCM CANopen INTERFACE CONNECTOR



These connections are polarity sensitive in terms of the terminals for 6-30V DC for CANopen external supply (CANopen_V+ and CANopen_GND / V-).

The CANopen interface female 5-pin connector must be wired in accordance with the Table in Subsection 1.2.1. The correct wiring will provide the electrical connection shown in Fig. 2.2.



Please check it twice to make sure that your wiring is OK!

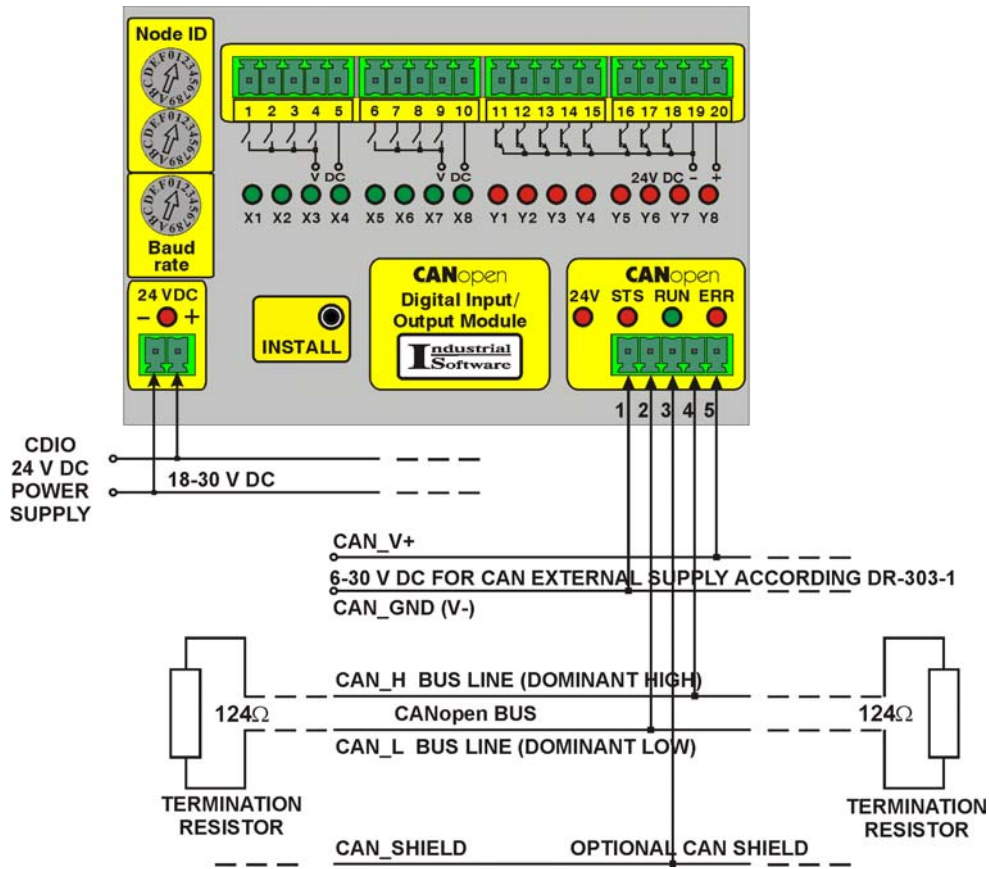

Fig. 2.2

The length of the CANopen BUS is in accordance with the recommendations of the document *CiA Draft Standard 301 - CANopen Application Layer and Communication Profile, Version 4.0, 16/06/1999*:

Baud Rate	Bus Length
1 Mbit/s	25 m
500 kbit/s	100 m
250 kbit/s	250 m
125 kbit/s	500 m

👉 The bus lines have to be terminated by termination resistors at both ends!

2.3. DIO88 DIGITAL I/O TERMINALS AND CONNECTIONS

Connecting CANopen DIO 88 INPUTS/OUTPUTS

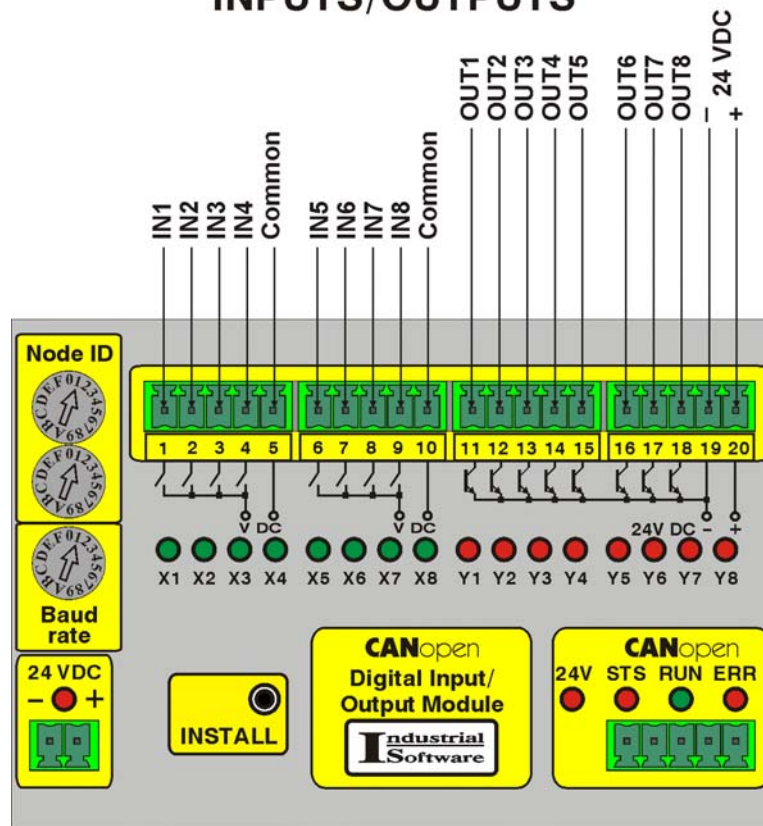

Fig. 2.3

2.3.1. Connection of Digital Inputs

The designation of the digital inputs is outlined in Table 2.3 and Table 2.4.

Table 2.3

Connector	Type	Description
1-5	terminal 1.5 mm ²	Used for connection of input 1 to input 4.
6-10	terminal 1.5 mm ²	Used for connection of input 5 to input 8.

Table 2.4

LED	Type	Description
X1 - X8	green	ON at logic 1, and OFF at logic 0 at corresponding digital input.

2.3.1.1. Circuit for commutation of “-”with dry contact

The connection of negative polarity external dry contacts to DIO88 digital inputs 1 to 4 is shown in Fig. 2.4. The same applies to the 5 to 8 inputs.

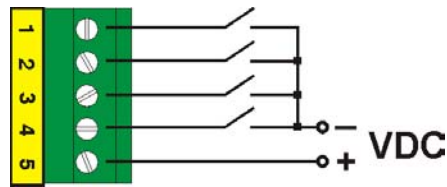

Fig. 2.4

2.3.1.2. Circuit for connection with NPN transistor

The connection of external NPN transistor to DIO88 digital inputs 1 to 4 is shown in Fig. 2.5. The same applies to the 5 to 8 inputs.

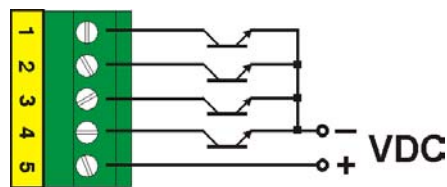

Fig. 2.5

2.3.1.3. Mixed connection with common +

The mixed connection to DIO88 digital inputs 1 to 4 is shown in Fig. 2.6. The same applies to the 5 to 8 inputs.

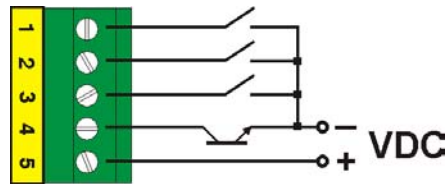

Fig. 2.6

2.3.1.4. Circuit for commutation of “+”with dry contact

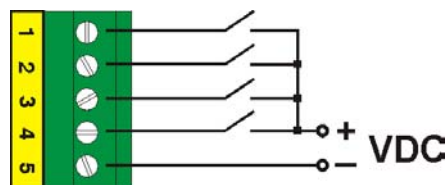

Fig. 2.7

2.3.1.5. Circuit for connection with PNP transistor

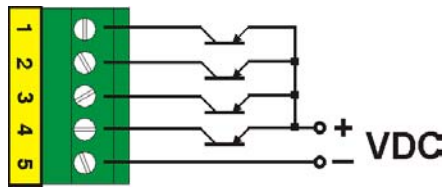

Fig. 2.8

2.3.1.6. Mixed connection with common -

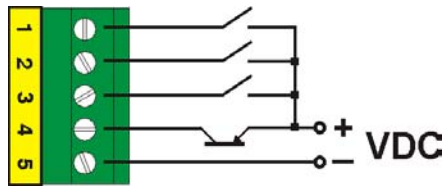

Fig. 2.9



Attention: The polarity of the switch-over voltage must be strictly observed.



Attention: Any connection of 220/100V to the 24 V digital inputs may damage the module.

2.3.2. Connection of Digital Outputs

The designation of the digital outputs is outlined in Table 2.5 and Table 2.6.

Table 2.5

Connector	Type	Description
11 - 18	terminal 1.5 mm ²	Digital outputs 1 to 8.
19 - 20	terminal 1.5 mm ²	Auxiliary 24 V DC power supply to the digital outputs module.

Table 2.6

LED	Type	Description
Y1 - Y8	red	ON at logic 1 and OFF at logic 0 at logic output

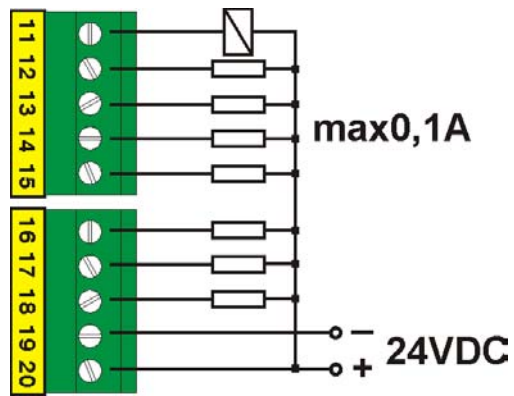

Fig. 2.10



CHAPTER 3

USING CANopen DIO88 AS PUSHER ACTUATOR CONTROL

- 3.1. GENERAL**
- 3.2. CRCM CONNECTIONS TO PUSHER HARDWARE**
- 3.3. DIO88 CONNECTIONS TO PUSHER HARDWARE**
 - 3.3.1. Actuator Control Interface**
 - 3.3.1.1. Actuator with PUSH / RETRACT inputs
 - 3.3.1.2. Actuator with ACTION / DIRECTION inputs
 - 3.3.2. Actuator Feedback Inputs**
 - 3.3.3. External Pushing Action Request**
 - 3.3.4. Percentage Divert Input Interface**
 - 3.3.5. Error Report Output Interface**

3.1. GENERAL

Scope

The Pusher unit provides a positive method of transferring a tray or tote from one conveyor line to the other. It accomplishes this by pushing the tray or tote across a power roller bed then releasing it on the other line.

Operation

The Pusher unit has input from an upstream conveyor and 2 outputs to downstream conveyors. When a tray or tote is seen at the upstream conveyor unit and the Pusher is clear it will convey on the Pusher unit. Once the tray or tote is positioned on the unit it will either be pushed to the other line or continue on the present line.

The routing decision can be made by Pusher or by an outside controller. Only simple routing decisions can be made by the Pusher itself (size, percentage divert, etc.). The Pusher controllers can receive routing commands over the CANopen network or with hardware inputs. CRCM module is used to control zone A and zone B of the Pusher and DIO88 is used to control the actuator of the Pusher. CRCM communicates to the upstream, downstream and DIO88 over CANopen network.

Below shows a typical application of a Pusher unit. The upstream and downstream conveyor can have 1 to 4 zones. A tray or tote will accumulate on the upstream zone until the Pusher is clear and the Pusher is in the home position. This is accomplished by selecting singulate mode for upstream CRCM. When the Pusher is ready it will release the upstream CRCM.

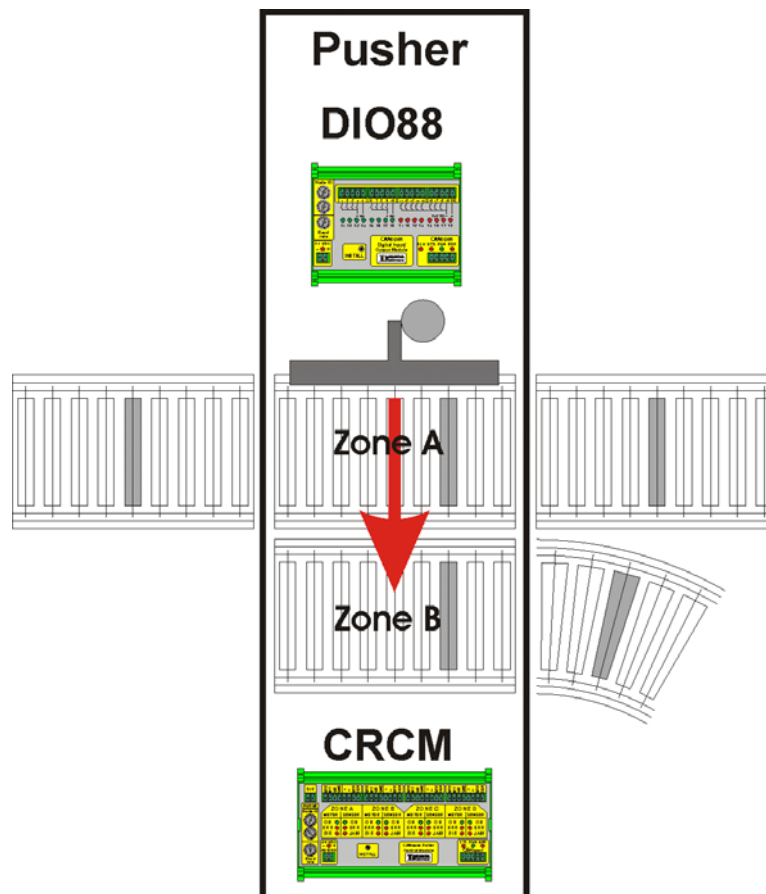

Fig. 3.1

CANopen DIO 88 acting as a Pusher Actuator Control

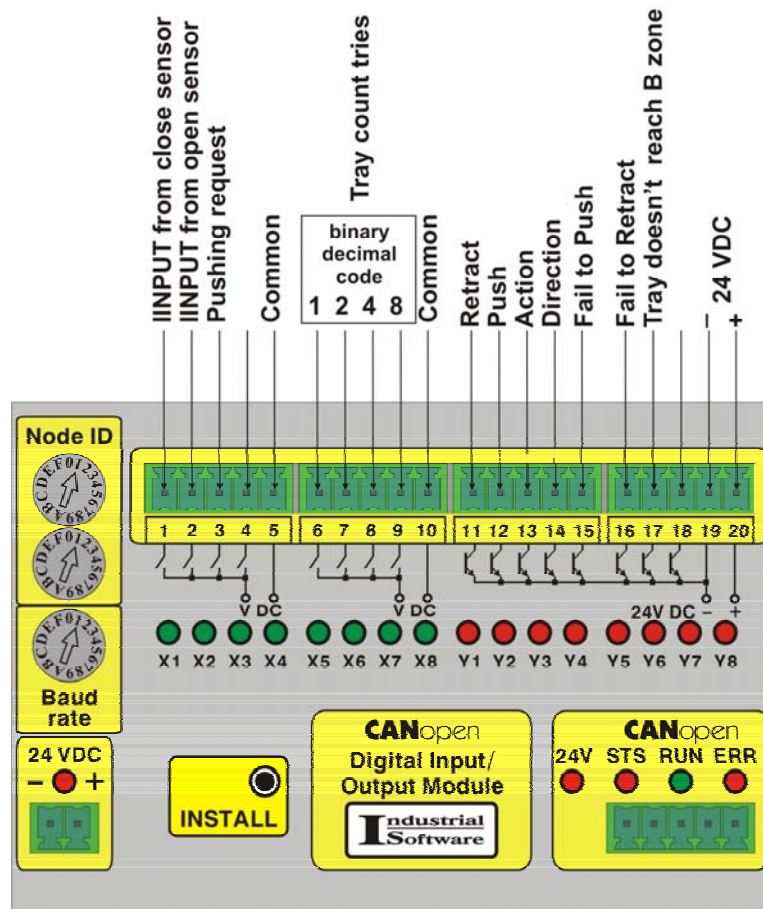

Fig. 3.3

Pin-out Description:

3.3.1. Actuator Control Interface

DIO88 supports 2 types of actuator interfaces:

3.3.1.1. Actuator with PUSH / RETRACT inputs

If your actuator uses 2 different inputs for PUSH action and RETRACT action connect **Y2** to push input of the actuator interface and connect **Y1** to retract input of the actuator interface.

3.3.1.2. Actuator with ACTION / DIRECTION inputs

If your actuator uses 1 input for action (run) and other input which defines the direction of the action (PUSH / RETRACT), then connect **Y3** to action input of the actuator interface and connect **Y4** to direction input of the actuator interface. Note that **Y4 = OFF** (transistor not switched) means forward action (PUSH) and **Y4 = ON** (transistor switched on) means backward action (RETRACT).

3.3.2. Actuator Feedback Inputs

If your actuator supports position switches for “END PUSH” and “END RETRACT” positions, connect them to **X1** and **X2** inputs of DIO88 respectively.

If your actuator does not supports such switches FORCE **X1** and **X2** to **ON** with external wiring, else DIO88 will always report “FAIL to PUSH” and “FAIL to RETRACT” errors.

3.3.3. External Pushing Action Request

If you have external pushing decision equipment (PLC, Scanner etc.) you may request pushing on next tray forcing ON on **X3**.

3.3.4. Percentage Divert Input Interface

You may connect some type of set-point device (HEX switch, PLC outputs etc.) to force percentage divert decision on Pusher. Place the Hexidecimal code from 1 to 0xF (15) on inputs **X5 – X8**.

If the code of the digit on inputs **X5 – X8** is **N**, then Pusher will push 1 of each **N** trays.

3.3.5. Error Report Output Interface

DIO88 uses 3 of its outputs to report last error occurred on the Pusher. **Y5 = ON** shows fail to “FAIL to PUSH” error, **Y6 = ON** shows “FAIL to RETRACT” error, **Y7 = ON** shows “TRAY DOESN'T REACH B ZONE” error.

You may connect these outputs to external equipment (PLC, Indicators, Lamps etc.) to maintain the Pusher. You may clear last error occurred, pressing Install button.

Some of the DIO88 properties (such as percentage divert) and timing parameters can be configured using RollOn Configuration Tool via DIO88 “Config & Watch” window.

For more information please refer to “CANopen RollOn Configuration Tool – User’s Manual”. For Manual installation rules of DIO88 please refer to Chapter 7 – “Configuring Powered Roller conveyor without PC, using CANopen Roller Control Module and CANopen DIO88” of “CANopen Roller/Merger Control Module – User’s Manual”.



CHAPTER 4

USING CANopen DIO88 AS GENERAL PURPOSE GENERIC I/O MODULE

DIO88 Digital I/O Module fully complies with CiA Draft Standard 401, Version 2.0 - Device Profile for Generic I/O Modules.

For more information please refer to this document.



CHAPTER 5

DIO88 ELECTRONIC DATA SHEET

- 5.1. GENERAL
- 5.2. DIO88 EDS FILE

5.1. GENERAL

The usage of devices in a communication network requires configuration of the device parameters and communication facilities. CANopen defines a standardized way to access these parameters via the **Object Dictionary (OD)**.

The Electronic Data Sheet is a general description of a device type.

For more details the user is referred to CiA Draft Standard Proposal 306, Version 1.0, 31/05/2000.

5.2. DIO88 EDS FILE

[FileInfo]

Filename=IndSoft_DIO.eds

FileVersion=1.0

FileRevision=1

Description=Input_Output

CreationTime=09:45AM

CreationDate=08-13-02

CreatedBy= Milen Naidenov

ModificationTime=12:50AM

ModificationDate=08-13-02

ModifiedBy=Milen Naidenov

[DeviceInfo]

VendorName="Industrial Software"

VendorNumber=0x00000049

ProductName="DIO 88"

ProductNumber=0x004F4944

RevisionNumber=0x00040004

BaudRate_125=1

BaudRate_250=1

BaudRate_500=1

BaudRate_800=0

BaudRate_1000=1

SimpleBootUpSlave=1

SimpleBootUpMaster=0

NrOfRxPdo=4

NrOfTxPdo=4

[StandardDataTypes]

0x0001=0

0x0002=0

0x0003=0

0x0004=0

0x0005=1

0x0006=1

0x0007=1

0x0008=0

0x0009=1

0x000A=0

0x000B=0

0x000C=0

0x000D=0

0x000E=1

0x000F=0

0x0020=1

0x0021=1

0x0023=1

[MandatoryObjects]

SupportedObjects=0x03

1=0x1000

2=0x1001

3=0x1018

[1000]

SubNumber=0

ParameterName=Device Type

ObjectType=7

DataType=0x0007

AccessType=ro

DefaultValue=0x00030191

PDOMapping=0

[1001]

SubNumber=0

ParameterName=Error Register

ObjectType=7

DataType=0x0005
AccessType=ro
DefaultValue=0
PDOMapping=1

[1018]
SubNumber=5
ParameterName=Identity Object
ObjectType=9
DataType=0x0023

[1018sub0]
ParameterName=Number of entries
ObjectType=7
DataType=0x0005
AccessType=RO
DefaultValue=0x4
PDOMapping=0

[1018sub1]
ParameterName=Vendor ID
ObjectType=7
DataType=0x0007
AccessType=RO
LowLimit=
HighLimit=
DefaultValue=0x00000049
PDOMapping=0

[1018sub2]
ParameterName=Product Code
ObjectType=7
DataType=0x0007
AccessType=RO
LowLimit=
HighLimit=
DefaultValue=0x004F4944
PDOMapping=0

[1018sub3]

ParameterName=Revision Number

ObjectType=7

DataType=0x0007

AccessType=RO

LowLimit=

HighLimit=

DefaultValue=0x00040004

PDOMapping=0

[1018sub4]

ParameterName=Serial Number

ObjectType=7

DataType=0x0007

AccessType=RO

LowLimit=

HighLimit=

DefaultValue=0x00000A85

PDOMapping=0

[OptionalObjects]

SupportedObjects=39

1=0x1004

2=0x1005

3=0x100B

4=0x100C

5=0x100D

6=0x1010

7=0x1011

8=0x1014

9=0x1016

10=0x1017

11=0x1020

12=0x1400

13=0x1401

14=0x1402

15=0x1403

16=0x1600

17=0x1601

18=0x1602
19=0x1603
20=0x1800
21=0x1801
22=0x1802
23=0x1803
24=0x1A00
25=0x1A01
26=0x1A02
27=0x1A03
28=0x6000
29=0x6002
30=0x6003
31=0x6005
32=0x6006
33=0x6007
34=0x6008
35=0x6200
36=0x6202
37=0x6206
38=0x6207
39=0x6208

[1004]

SubNumber=3

ParameterName=Number of PDOs supported

[1004sub0]

ParameterName=Number of transmit and receive PDOs supported

ObjectType=

DataType=0x0007

LowLimit=0

HighLimit=0x01ff01ff

AccessType=ro

DefaultValue=0x00010000

PDOMapping=0

[1004sub1]

ParameterName=No synch. RxPDOs/TxPDOs

ObjectType=

DataType=0x0007

LowLimit=0

HighLimit=0x01ff01ff

AccessType=ro

DefaultValue=0x00010000

PDOMapping=0

[1004sub2]

ParameterName=No asynch. RxPDOs/TxPDOs

ObjectType=

ParameterValue=0x00020002

DataType=0x0007

LowLimit=0

HighLimit=0x01ff01ff

AccessType=ro

DefaultValue=0x00000001

PDOMapping=0

[1005]

SubNumber=0

ParameterName=COB-ID SYNC-message

ObjectType=7

DataType=0x0007

LowLimit=

HighLimit=

AccessType=rw

DefaultValue=0x00000080

PDOMapping=0

[100B]

SubNumber=0

ParameterName=Node-ID

ObjectType=7

DataType=0x0007

LowLimit=

HighLimit=

AccessType=ro
DefaultValue=0
PDOMapping=0

[100C]
SubNumber=0
ParameterName=Guard Time
ObjectType=7
DataType=0x0007
LowLimit=
HighLimit=
AccessType=rw
DefaultValue=0
PDOMapping=0

[100D]
SubNumber=0
ParameterName=Life time factor
ObjectType=7
DataType=0x0007
LowLimit=
HighLimit=
AccessType=rw
DefaultValue=3
PDOMapping=0

[1400]
SubNumber=3
ParameterName=Receive PDO1 Parameter
ObjectType=9
DataType=0x0020

[1400sub0]
ParameterName=Number of entries
ObjectType=7
DataType=0x0005
AccessType=RO
LowLimit=2
HighLimit=3

DefaultValue=0x3

PDOMapping=0

[1400sub1]

ParameterName=COB-ID

ObjectType=7

DataType=0x0007

AccessType=RW

DefaultValue=0x00000200

PDOMapping=0

[1400sub2]

ParameterName=Transmission type

ObjectType=7

DataType=0x0005

AccessType=RW

DefaultValue=254

PDOMapping=0

[1401]

SubNumber=3

ParameterName=Receive PDO2 Parameter

ObjectType=9

DataType=0x0020

[1401sub0]

ParameterName=Number of entries

ObjectType=7

DataType=0x0005

AccessType=RO

LowLimit=2

HighLimit=3

DefaultValue=0x3

PDOMapping=0

[1401sub1]

ParameterName=COB-ID

ObjectType=7

DataType=0x0007

AccessType=RW
DefaultValue=0x00000300
PDOMapping=0

[1401sub2]
ParameterName=Transmission type
ObjectType=7
DataType=0x0005
AccessType=RW
DefaultValue=254
PDOMapping=0

[1402]
SubNumber=3
ParameterName=Receive PDO3 Parameter
ObjectType=9
DataType=0x0020

[1402sub0]
ParameterName=Number of entries
ObjectType=7
DataType=0x0005
AccessType=RO
LowLimit=2
HighLimit=3
DefaultValue=0x3
PDOMapping=0

[1402sub1]
ParameterName=COB-ID
ObjectType=7
DataType=0x0007
AccessType=RW
DefaultValue=0x00000400
PDOMapping=0

[1402sub2]
ParameterName=Transmission type
ObjectType=7

DataType=0x0005
AccessType=RW
DefaultValue=254
PDOMapping=0

[1403]

SubNumber=3
ParameterName=Receive PDO3 Parameter
ObjectType=9
DataType=0x0020

[1403sub0]

ParameterName=Number of entries
ObjectType=7
DataType=0x0005
AccessType=RO
LowLimit=2
HighLimit=3
DefaultValue=0x3
PDOMapping=0

[1403sub1]

ParameterName=COB-ID
ObjectType=7
DataType=0x0007
AccessType=RW
DefaultValue=0x00000500
PDOMapping=0

[1403sub2]

ParameterName=Transmission type
ObjectType=7
DataType=0x0005
AccessType=RW
DefaultValue=254
PDOMapping=0

[1600]

SubNumber=9

ParameterName=Receive PDO1 mapping

ObjectType=9

DataType=0x0021

[1600sub0]

ParameterName=Number of mapped objects

ObjectType=7

DataType=0x0007

AccessType=RW

DefaultValue=0x5

PDOMapping=0

LowLimit=0

HighLimit=8

[1600sub1]

ParameterName=1.mapped object

ObjectType=7

DataType=0x0007

AccessType=RW

DefaultValue=0x20020108

PDOMapping=0

[1600sub2]

ParameterName=2.mapped object

ObjectType=7

DataType=0x0007

AccessType=RW

DefaultValue=0x00050008

PDOMapping=0

[1600sub3]

ParameterName=3.mapped object

ObjectType=7

DataType=0x0007

AccessType=RW

DefaultValue=0x00050008

PDOMapping=0

[1600sub4]

ParameterName=4.mapped object

ObjectType=7

DataType=0x0007

AccessType=RW

DefaultValue=0x00050008

PDOMapping=0

[1600sub5]

ParameterName=5.mapped object

ObjectType=7

DataType=0x0007

AccessType=RW

DefaultValue=0x00070008

PDOMapping=0

[1600sub6]

ParameterName=6.mapped object

ObjectType=7

DataType=0x0007

AccessType=RW

DefaultValue=0

PDOMapping=0

[1600sub7]

ParameterName=7.mapped object

ObjectType=7

DataType=0x0007

AccessType=RW

DefaultValue=0

PDOMapping=0

[1600sub8]

ParameterName=8.mapped object

ObjectType=7

DataType=0x0007

AccessType=RW

DefaultValue=0

PDOMapping=0

[1601]

SubNumber=9

ParameterName=Receive PDO2 mapping

ObjectType=9

DataType=0x0021

[1601sub0]

ParameterName=Number of mapped objects

ObjectType=7

DataType=0x0007

AccessType=RW

DefaultValue=0x5

PDOMapping=0

LowLimit=0

HighLimit=8

[1601sub1]

ParameterName=1.mapped object

ObjectType=7

DataType=0x0007

AccessType=RW

DefaultValue=0x00050008

PDOMapping=0

[1601sub2]

ParameterName=2.mapped object

ObjectType=7

DataType=0x0007

AccessType=RW

DefaultValue=0x00050008

PDOMapping=0

[1601sub3]

ParameterName=3.mapped object

ObjectType=7

DataType=0x0007

AccessType=RW

DefaultValue=0x00050008

PDOMapping=0

[1601sub4]

ParameterName=4.mapped object

ObjectType=7

DataType=0x0007

AccessType=RW

DefaultValue=0x20020208

PDOMapping=0

[1601sub5]

ParameterName=5.mapped object

ObjectType=7

DataType=0x0007

AccessType=RW

DefaultValue=0x00070008

PDOMapping=0

[1601sub6]

ParameterName=6.mapped object

ObjectType=7

DataType=0x0007

AccessType=RW

DefaultValue=0

PDOMapping=0

[1601sub7]

ParameterName=7.mapped object

ObjectType=7

DataType=0x0007

AccessType=RW

DefaultValue=0

PDOMapping=0

[1601sub8]

ParameterName=8.mapped object

ObjectType=7

DataType=0x0007

AccessType=RW

DefaultValue=0

PDOMapping=0

[1602]

SubNumber=9

ParameterName=Receive PDO3 mapping

ObjectType=9

DataType=0x0021

[1602sub0]

ParameterName=Number of mapped objects

ObjectType=7

DataType=0x0007

AccessType=RW

DefaultValue=0x8

PDOMapping=0

LowLimit=0

HighLimit=8

[1602sub1]

ParameterName=1.mapped object

ObjectType=7

DataType=0x0007

AccessType=RW

DefaultValue=0

PDOMapping=0

[1602sub2]

ParameterName=2.mapped object

ObjectType=7

DataType=0x0007

AccessType=RW

DefaultValue=0

PDOMapping=0

[1602sub3]

ParameterName=3.mapped object

ObjectType=7

DataType=0x0007

AccessType=RW

DefaultValue=0

PDOMapping=0

[1602sub4]

ParameterName=4.mapped object

ObjectType=7

DataType=0x0007

AccessType=RW

DefaultValue=0

PDOMapping=0

[1602sub5]

ParameterName=5.mapped object

ObjectType=7

DataType=0x0007

AccessType=RW

DefaultValue=0

PDOMapping=0

[1602sub6]

ParameterName=6.mapped object

ObjectType=7

DataType=0x0007

AccessType=RW

DefaultValue=0

PDOMapping=0

[1602sub7]

ParameterName=7.mapped object

ObjectType=7

DataType=0x0007

AccessType=RW

DefaultValue=0

PDOMapping=0

[1602sub8]

ParameterName=8.mapped object

ObjectType=7

DataType=0x0007

AccessType=RW

DefaultValue=0

PDOMapping=0

[1603]

SubNumber=9

ParameterName=Receive PDO4 mapping

ObjectType=9

DataType=0x0021

[1603sub0]

ParameterName=Number of mapped objects

ObjectType=7

DataType=0x0007

AccessType=RW

DefaultValue=0x8

PDOMapping=0

LowLimit=0

HighLimit=8

[1603sub1]

ParameterName=1.mapped object

ObjectType=7

DataType=0x0007

AccessType=RW

DefaultValue=0

PDOMapping=0

[1603sub2]

ParameterName=2.mapped object

ObjectType=7

DataType=0x0007

AccessType=RW

DefaultValue=0

PDOMapping=0

[1603sub3]

ParameterName=3.mapped object

ObjectType=7

DataType=0x0007

AccessType=RW

DefaultValue=0

PDOMapping=0

[1603sub4]

ParameterName=4.mapped object

ObjectType=7

DataType=0x0007

AccessType=RW

DefaultValue=0

PDOMapping=0

[1603sub5]

ParameterName=5.mapped object

ObjectType=7

DataType=0x0007

AccessType=RW

DefaultValue=0

PDOMapping=0

[1603sub6]

ParameterName=6.mapped object

ObjectType=7

DataType=0x0007

AccessType=RW

DefaultValue=0

PDOMapping=0

[1603sub7]

ParameterName=7.mapped object

ObjectType=7

DataType=0x0007

AccessType=RW

DefaultValue=0

PDOMapping=0

[1603sub8]

ParameterName=8.mapped object

ObjectType=7

DataType=0x0007

AccessType=RW

DefaultValue=0

PDOMapping=0

[1800]
SubNumber=3
ParameterName=Transmit PDO1 Parameter
ObjectType=9
DataType=0x0020

[1800sub0]
ParameterName=Number of entries
ObjectType=7
DataType=0x0005
AccessType=RO
LowLimit=2
HighLimit=5
DefaultValue=0x3
PDOMapping=0

[1800sub1]
ParameterName=COB-ID
ObjectType=7
DataType=0x0007
AccessType=RW
DefaultValue=0x00000180
PDOMapping=0

[1800sub2]
ParameterName=Transmission type
ObjectType=7
DataType=0x0005
AccessType=RW
DefaultValue=254
PDOMapping=0

[1801]
SubNumber=3
ParameterName=Transmit PDO2 Parameter
ObjectType=9
DataType=0x0020

[1801sub0]

ParameterName=Number of entries

ObjectType=7

DataType=0x0005

AccessType=RO

LowLimit=2

HighLimit=5

DefaultValue=0x3

PDOMapping=0

[1801sub1]

ParameterName=COB-ID

ObjectType=7

DataType=0x0007

AccessType=RW

DefaultValue=0x80000280

PDOMapping=0

[1801sub2]

ParameterName=Transmission type

ObjectType=7

DataType=0x0005

AccessType=RW

DefaultValue=254

PDOMapping=0

[1802]

SubNumber=3

ParameterName=Transmit PDO3 Parameter

ObjectType=9

DataType=0x0020

[1802sub0]

ParameterName=Number of entries

ObjectType=7

DataType=0x0005

AccessType=RO

LowLimit=2

HighLimit=5

DefaultValue=0x3

PDOMapping=0

[1802sub1]

ParameterName=COB-ID

ObjectType=7

DataType=0x0007

AccessType=RW

DefaultValue=0x80000380

PDOMapping=0

[1802sub2]

ParameterName=Transmission type

ObjectType=7

DataType=0x0005

AccessType=RW

DefaultValue=254

PDOMapping=0

[1803]

SubNumber=3

ParameterName=Transmit PDO4 Parameter

ObjectType=9

DataType=0x0020

[1803sub0]

ParameterName=Number of entries

ObjectType=7

DataType=0x0005

AccessType=RO

LowLimit=2

HighLimit=5

DefaultValue=0x3

PDOMapping=0

[1803sub1]

ParameterName=COB-ID

ObjectType=7

DataType=0x0007

AccessType=RW
DefaultValue=0x80000480
PDOMapping=0

[1803sub2]

ParameterName=Transmission type
ObjectType=7
DataType=0x0005
AccessType=RW
DefaultValue=254
PDOMapping=0

[1A00]

SubNumber=9
ParameterName=Transmite PDO1 mapping
ObjectType=9
DataType=0x0021

[1A00sub0]

ParameterName=Number of mapped objects
ObjectType=7
DataType=0x0007
AccessType=RW
DefaultValue=0x5
PDOMapping=0
LowLimit=0
HighLimit=8

[1A00sub1]

ParameterName=1.mapped object
ObjectType=7
DataType=0x0007
AccessType=RW
DefaultValue=0x20010108
PDOMapping=0

[1A00sub2]

ParameterName=2.mapped object
ObjectType=7

DataType=0x0007
AccessType=RW
DefaultValue=0x20010208
PDOMapping=0

[1A00sub3]
ParameterName=3.mapped object
ObjectType=7
DataType=0x0007
AccessType=RW
DefaultValue=0x20010308
PDOMapping=0

[1A00sub4]
ParameterName=4.mapped object
ObjectType=7
DataType=0x0007
AccessType=RW
DefaultValue=0x20010408
PDOMapping=0

[1A00sub5]
ParameterName=5.mapped object
ObjectType=7
DataType=0x0007
AccessType=RW
DefaultValue=0x200A0020
PDOMapping=0

[1A00sub6]
ParameterName=6.mapped object
ObjectType=7
DataType=0x0007
AccessType=RW
DefaultValue=0
PDOMapping=0

[1A00sub7]

ParameterName=7.mapped object

ObjectType=7

DataType=0x0007

AccessType=RW

DefaultValue=0

PDOMapping=0

[1A00sub8]

ParameterName=8.mapped object

ObjectType=7

DataType=0x0007

AccessType=RW

DefaultValue=0

PDOMapping=0

[1A01]

SubNumber=9

ParameterName=Transmite PDO2 mapping

ObjectType=9

DataType=0x0021

[1A01sub0]

ParameterName=Number of mapped objects

ObjectType=7

DataType=0x0007

AccessType=RW

DefaultValue=0x0

PDOMapping=0

LowLimit=0

HighLimit=8

[1A01sub1]

ParameterName=1.mapped object

ObjectType=7

DataType=0x0007

AccessType=RW

DefaultValue=0

PDOMapping=0

[1A01sub2]

ParameterName=2.mapped object

ObjectType=7

DataType=0x0007

AccessType=RW

DefaultValue=0

PDOMapping=0

[1A01sub3]

ParameterName=3.mapped object

ObjectType=7

DataType=0x0007

AccessType=RW

DefaultValue=0

PDOMapping=0

[1A01sub4]

ParameterName=4.mapped object

ObjectType=7

DataType=0x0007

AccessType=RW

DefaultValue=0

PDOMapping=0

[1A01sub5]

ParameterName=5.mapped object

ObjectType=7

DataType=0x0007

AccessType=RW

DefaultValue=0

PDOMapping=0

[1A01sub6]

ParameterName=6.mapped object

ObjectType=7

DataType=0x0007

AccessType=RW

DefaultValue=0

PDOMapping=0

[1A01sub7]

ParameterName=7.mapped object

ObjectType=7

DataType=0x0007

AccessType=RW

DefaultValue=0

PDOMapping=0

[1A01sub8]

ParameterName=8.mapped object

ObjectType=7

DataType=0x0007

AccessType=RW

DefaultValue=0

PDOMapping=0

[1A02]

SubNumber=9

ParameterName=Transmite PDO3 mapping

ObjectType=9

DataType=0x0021

[1A02sub0]

ParameterName=Number of mapped objects

ObjectType=7

DataType=0x0007

AccessType=RW

DefaultValue=0x0

PDOMapping=0

LowLimit=0

HighLimit=8

[1A02sub1]

ParameterName=1.mapped object

ObjectType=7

DataType=0x0007

AccessType=RW

DefaultValue=0

PDOMapping=0

[1A02sub2]

ParameterName=2.mapped object

ObjectType=7

DataType=0x0007

AccessType=RW

DefaultValue=0

PDOMapping=0

[1A02sub3]

ParameterName=3.mapped object

ObjectType=7

DataType=0x0007

AccessType=RW

DefaultValue=0

PDOMapping=0

[1A02sub4]

ParameterName=4.mapped object

ObjectType=7

DataType=0x0007

AccessType=RW

DefaultValue=0

PDOMapping=0

[1A02sub5]

ParameterName=5.mapped object

ObjectType=7

DataType=0x0007

AccessType=RW

DefaultValue=0

PDOMapping=0

[1A02sub6]

ParameterName=6.mapped object

ObjectType=7

DataType=0x0007

AccessType=RW

DefaultValue=0

PDOMapping=0

[1A02sub7]

ParameterName=7.mapped object

ObjectType=7

DataType=0x0007

AccessType=RW

DefaultValue=0

PDOMapping=0

[1A02sub8]

ParameterName=8.mapped object

ObjectType=7

DataType=0x0007

AccessType=RW

DefaultValue=0

PDOMapping=0

[1A03]

SubNumber=9

ParameterName=Transmite PDO4 mapping

ObjectType=9

DataType=0x0021

[1A03sub0]

ParameterName=Number of mapped objects

ObjectType=7

DataType=0x0007

AccessType=RW

DefaultValue=0x0

PDOMapping=0

LowLimit=0

HighLimit=8

[1A03sub1]

ParameterName=1.mapped object

ObjectType=7

DataType=0x0007

AccessType=RW

DefaultValue=0

PDOMapping=0

[1A03sub2]

ParameterName=2.mapped object

ObjectType=7

DataType=0x0007

AccessType=RW

DefaultValue=0

PDOMapping=0

[1A03sub3]

ParameterName=3.mapped object

ObjectType=7

DataType=0x0007

AccessType=RW

DefaultValue=0

PDOMapping=0

[1A03sub4]

ParameterName=4.mapped object

ObjectType=7

DataType=0x0007

AccessType=RW

DefaultValue=0

PDOMapping=0

[1A03sub5]

ParameterName=5.mapped object

ObjectType=7

DataType=0x0007

AccessType=RW

DefaultValue=0

PDOMapping=0

[1A03sub6]

ParameterName=6.mapped object

ObjectType=7

DataType=0x0007

AccessType=RW

DefaultValue=0

PDOMapping=0

[1A03sub7]

ParameterName=7.mapped object

ObjectType=7

DataType=0x0007

AccessType=RW

DefaultValue=0

PDOMapping=0

[1A03sub8]

ParameterName=8.mapped object

ObjectType=7

DataType=0x0007

AccessType=RW

DefaultValue=0

PDOMapping=0

[6000]

SubNumber=1

ParameterName=Input_6000

ObjectType=5

DataType=0x0005

[6000sub0]

ParameterName=Input_6000

ObjectType=7

DataType=0x0005

AccessType=RO

DefaultValue=0x01

PDOMapping=0

[6000sub1]

ParameterName= Input_6000.Port_In

ObjectType=5

DataType=0x0005

AccessType=RW

DefaultValue=0x0

PDOMapping=1

[6002]

SubNumber=1

ParameterName=Input_6002

ObjectType=5

DataType=0x0005

[6002sub0]

ParameterName=Input_6002

ObjectType=7

DataType=0x0005

AccessType=RO

DefaultValue=0x01

PDOMapping=0

[6002sub1]

ParameterName= Input_6002.Port_In

ObjectType=5

DataType=0x0005

AccessType=RW

DefaultValue=0x0

PDOMapping=1

[6003]

SubNumber=1

ParameterName=Input_6003

ObjectType=5

DataType=0x0005

[6003sub0]

ParameterName=Input_6003

ObjectType=7

DataType=0x0005

AccessType=RO

DefaultValue=0x01

PDOMapping=0

[6003sub1]

ParameterName= Input_6003.Port_In

ObjectType=5

DataType=0x0005
AccessType=RW
DefaultValue=0x0
PDOMapping=1

[6005]

SubNumber=0
ParameterName=Input_6000
ObjectType=5
DataType=0x000E
AccessType=RW
DefaultValue=0x1
PDOMapping=1

[6006]

SubNumber=1
ParameterName=Input_6006
ObjectType=5
DataType=0x0005

[6006sub0]

ParameterName=Input_6006
ObjectType=7
DataType=0x0005
AccessType=RO
DefaultValue=0x01
PDOMapping=0

[6006sub1]

ParameterName= Input_6006.Port_In
ObjectType=5
DataType=0x0005
AccessType=RW
DefaultValue=0x0
PDOMapping=1

[6007]

SubNumber=1
ParameterName=Input_6007

ObjectType=5
DataType=0x0005

[6007sub0]
ParameterName=Input_6007
ObjectType=7
DataType=0x0005
AccessType=RO
DefaultValue=0x01
PDOMapping=0

[6007sub1]
ParameterName= Input_6007.Port_In
ObjectType=5
DataType=0x0005
AccessType=RW
DefaultValue=0x0
PDOMapping=1

[6008]
SubNumber=1
ParameterName=Input_6008
ObjectType=5
DataType=0x0005

[6008sub0]
ParameterName=Input_6008
ObjectType=7
DataType=0x0005
AccessType=RO
DefaultValue=0x01
PDOMapping=0

[6008sub1]
ParameterName= Input_6008.Port_In
ObjectType=5
DataType=0x0005
AccessType=RW
DefaultValue=0x0

PDOMapping=1

[6200]

SubNumber=1

ParameterName=Output_6200

ObjectType=5

DataType=0x0005

[6200sub0]

ParameterName=Output_6200

ObjectType=7

DataType=0x0005

AccessType=RO

DefaultValue=0x01

PDOMapping=0

[6200sub1]

ParameterName=Output_6200.Port_Out

ObjectType=5

DataType=0x0005

AccessType=RW

DefaultValue=0x00

PDOMapping=1

[6202]

SubNumber=1

ParameterName=Output_6202

ObjectType=5

DataType=0x0005

[6202sub0]

ParameterName=Output_6202

ObjectType=7

DataType=0x0005

AccessType=RO

DefaultValue=0x01

PDOMapping=0

[6202sub1]
ParameterName=Output_6202.Port_Out
ObjectType=5
DataType=0x0005
AccessType=RW
DefaultValue=0x00
PDOMapping=1

[6206]
SubNumber=1
ParameterName=Output_6206
ObjectType=5
DataType=0x0005

[6206sub0]
ParameterName=Output_6206
ObjectType=7
DataType=0x0005
AccessType=RO
DefaultValue=0x01
PDOMapping=0

[6206sub1]
ParameterName=Output_6206.Port_Out
ObjectType=5
DataType=0x0005
AccessType=RW
DefaultValue=0x00
PDOMapping=1

[6207]
SubNumber=1
ParameterName=Output_6207
ObjectType=5
DataType=0x0005

[6207sub0]
ParameterName=Output_6207
ObjectType=7

DataType=0x0005
AccessType=RO
DefaultValue=0x01
PDOMapping=0

[6207sub1]

ParameterName=Output_6207.Port_Out
ObjectType=5
DataType=0x0005
AccessType=RW
DefaultValue=0xFF
PDOMapping=1

[6208]

SubNumber=1
ParameterName=Output_6208
ObjectType=5
DataType=0x0005

[6208sub0]

ParameterName=Output_6208
ObjectType=7
DataType=0x0005
AccessType=RO
DefaultValue=0x01
PDOMapping=0

[6208sub1]

ParameterName=Output_6208.Port_Out
ObjectType=5
DataType=0x0005
AccessType=RW
DefaultValue=0x00
PDOMapping=1

[ManufactureObjects]

SupportedObjects=14
1=0x2001
2=0x2002

3=0x2003
4=0x2004
5=0x2005
6=0x2006
7=0x2007
8=0x2008
9=0x2009
10=0x200A
11=0x200B
12=0x200C
13=0x200D
14=0x200E

[2001]

SubNumber=0
ParameterName=Command
ObjectType=7
DataType=0x0005
AccessType=RW
DefaultValue=0x00
PDOMapping=1

[2002]

SubNumber=0
ParameterName=Respons
ObjectType=7
DataType=0x0005
AccessType=RW
DefaultValue=0x00
PDOMapping=1

[2003]

SubNumber=0
ParameterName=Tray_Count
ObjectType=7
DataType=0x0007
AccessType=RW
DefaultValue=0x00
PDOMapping=1

[2004]

SubNumber=1

ParameterName=InputS

ObjectType=5

DataType=0x0005

[2004sub0]

ParameterName=InputS

ObjectType=7

DataType=0x0005

AccessType=RO

DefaultValue=0x01

PDOMapping=0

[2004sub1]

ParameterName= InputS.Port_In

ObjectType=5

DataType=0x0005

AccessType=RW

DefaultValue=0xFF

PDOMapping=1

[2005]

SubNumber=1

ParameterName=OutputS

ObjectType=5

DataType=0x0005

[2005sub0]

ParameterName=OutputS

ObjectType=7

DataType=0x0005

AccessType=RO

DefaultValue=0x01

PDOMapping=0

[2005sub1]

ParameterName=OutputS.Port_Out

ObjectType=5

DataType=0x0005
AccessType=RW
DefaultValue=0x00
PDOMapping=1

[2006]
SubNumber=0
ParameterName=Min_Time
ObjectType=6
DataType=0x0006
AccessType=RW
DefaultValue=0x03E8
PDOMapping=1

[2007]
SubNumber=0
ParameterName=Max_Time
ObjectType=6
DataType=0x0006
AccessType=RW
DefaultValue=0x0BB8
PDOMapping=1

[2008]
SubNumber=0
ParameterName=Zone_A
ObjectType=7
DataType=0x0005
AccessType=RW
DefaultValue=0x00
PDOMapping=1

[2009]
SubNumber=0
ParameterName=Zone_B.ZoneB
ObjectType=5
DataType=0x0005
AccessType=RW
DefaultValue=0x00

PDOMapping=1

[200A]

SubNumber=0

ParameterName=Zone_D.ZoneD

ObjectType=5

DataType=0x0005

AccessType=RW

DefaultValue=0x00

PDOMapping=1

[200B]

SubNumber=0

ParameterName=Status_Z

ObjectType=7

DataType=0x0007

AccessType=RW

DefaultValue=0x00000000

PDOMapping=1

[200C]

SubNumber=0

ParameterName=Types

ObjectType=7

DataType=0x0005

AccessType=RW

DefaultValue=0x01

PDOMapping=1

[200D]

SubNumber=0

ParameterName=BootState

ObjectType=7

DataType=0x0005

AccessType=RW

DefaultValue=0x00

PDOMapping=1

[200E]
SubNumber=0
ParameterName=Befor_time
ObjectType=7
DataType=0x0006
AccessType=RW
DefaultValue=0x01F4
PDOMapping=1